

# E5A\*

ETAP tomorrow's light

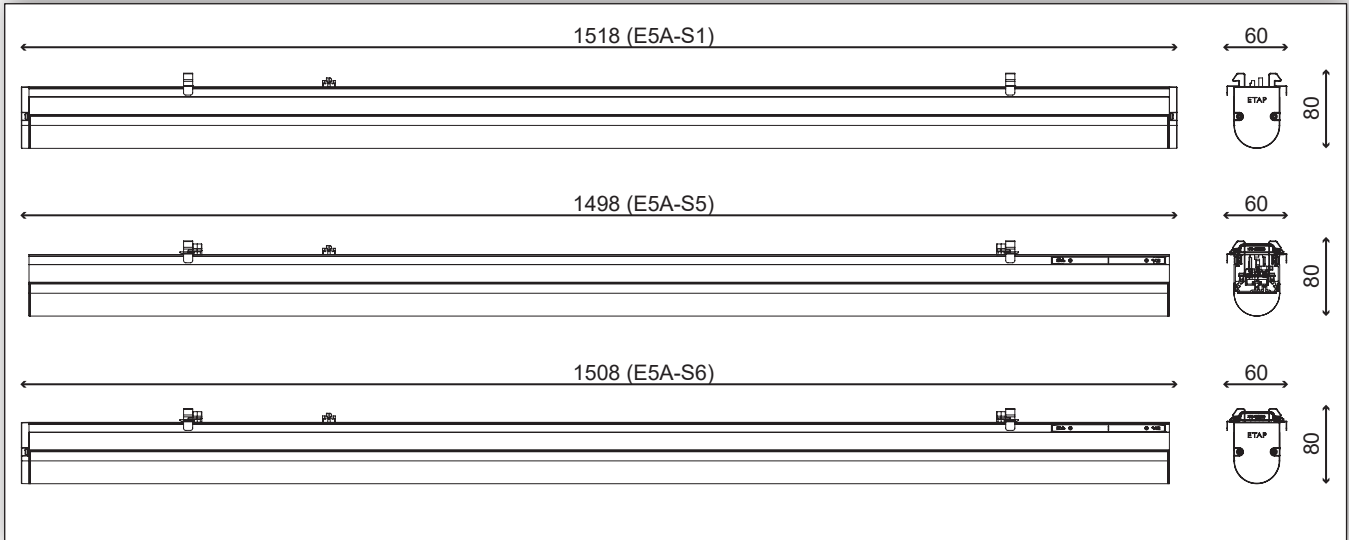

## BELANGRIJK - IMPORTANT - ACHTUNG - IMPORTANTE

### ELEKTRISCHE INSTALLATIE

Volg de aanduidingen in het armatuur.

### RACCORDEMENT ELECTRIQUE

Suivez les indications dans le luminaire.

### ELEKTRISCHER ANSCHLUSS

Beachten Sie die Angaben in der Leuchte.

### WIRING DIAGRAMS

Follow the indications in the luminaire.

### DIAGRAMA DE CABLEADO

Seguir las indicaciones en la luminaria.

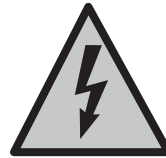

Optiek niet openen  
Optique ne pas ouvrir  
Optik nicht öffnen  
Do not open optics  
Óptica no se abren

## PLAATSING - EMPLACEMENT - ANORDNUNG - PLACING - COLOCACION

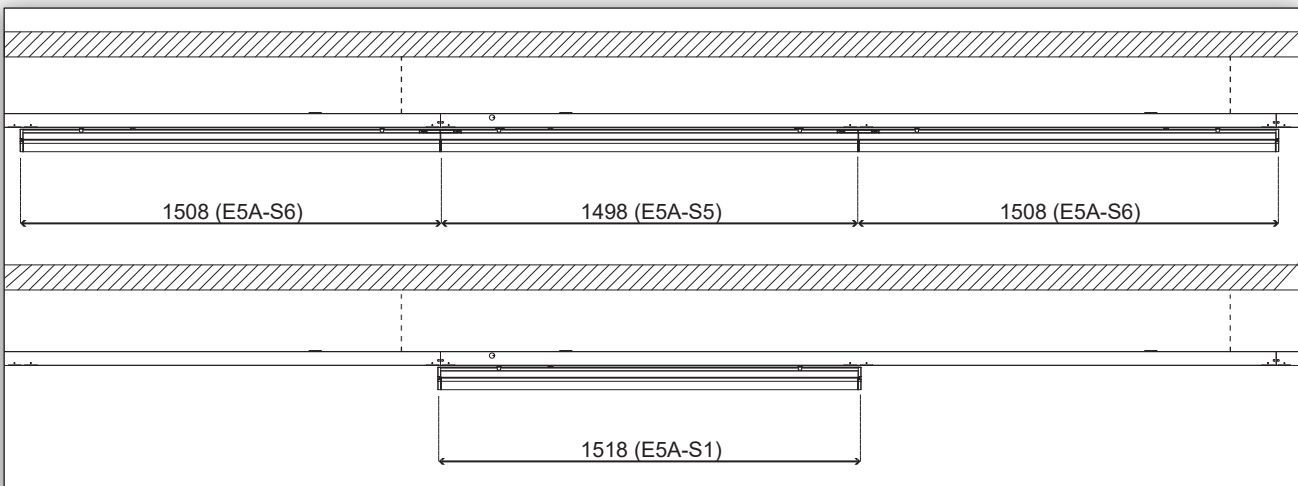

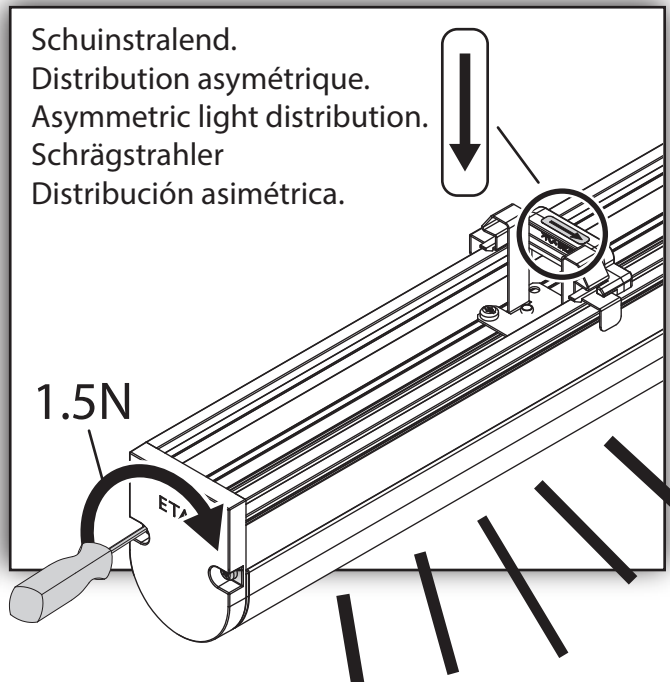
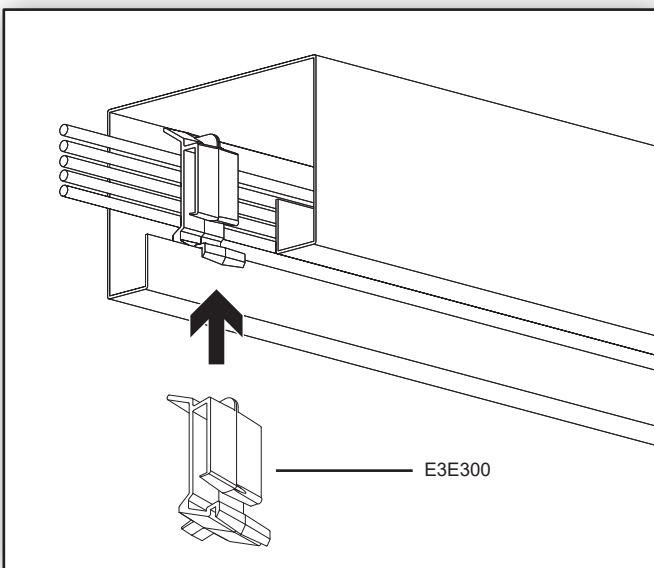
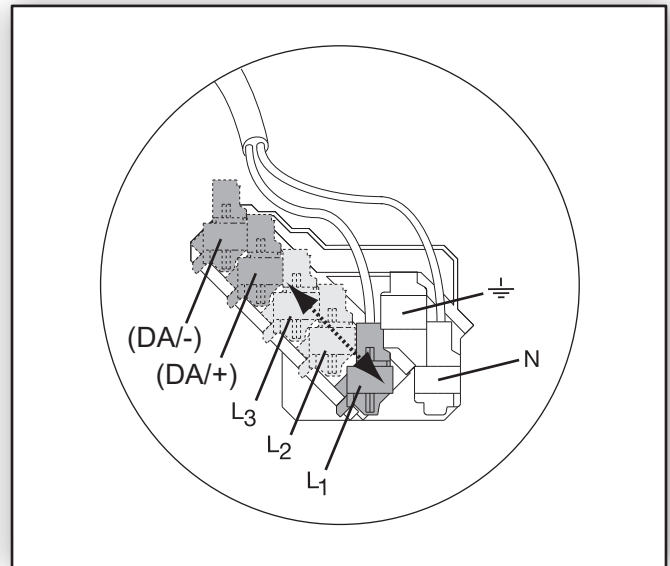
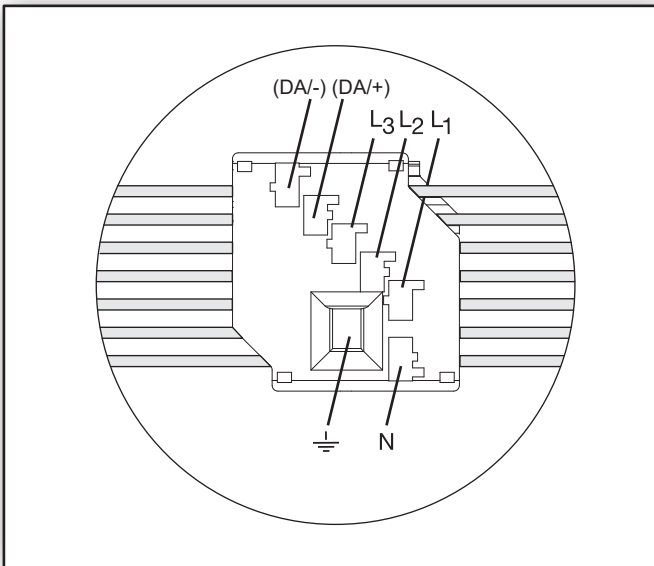
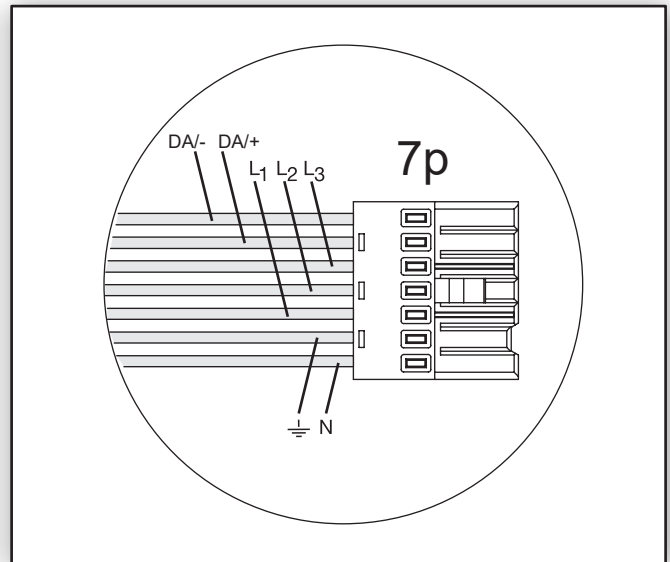
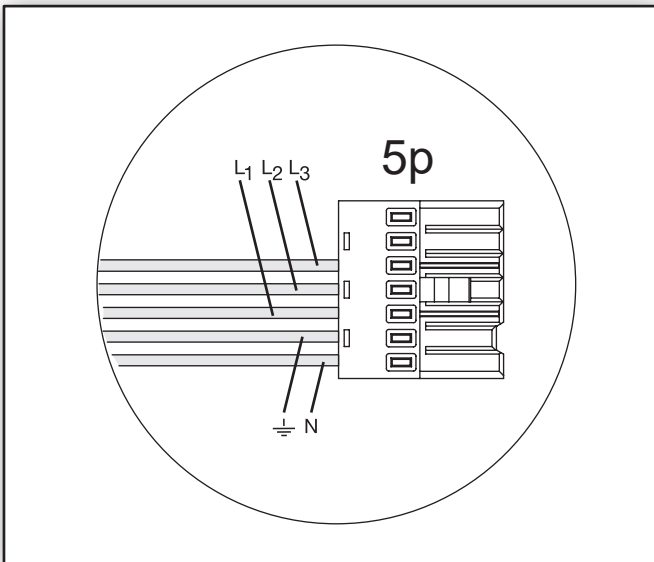

# INSTALLATIE | INSTALLATION | INSTALACION

Alleen renovatie / Seulement rénovation / Only renovation / Nur Renovierung / Sólo renovación

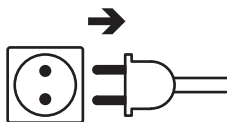
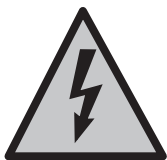
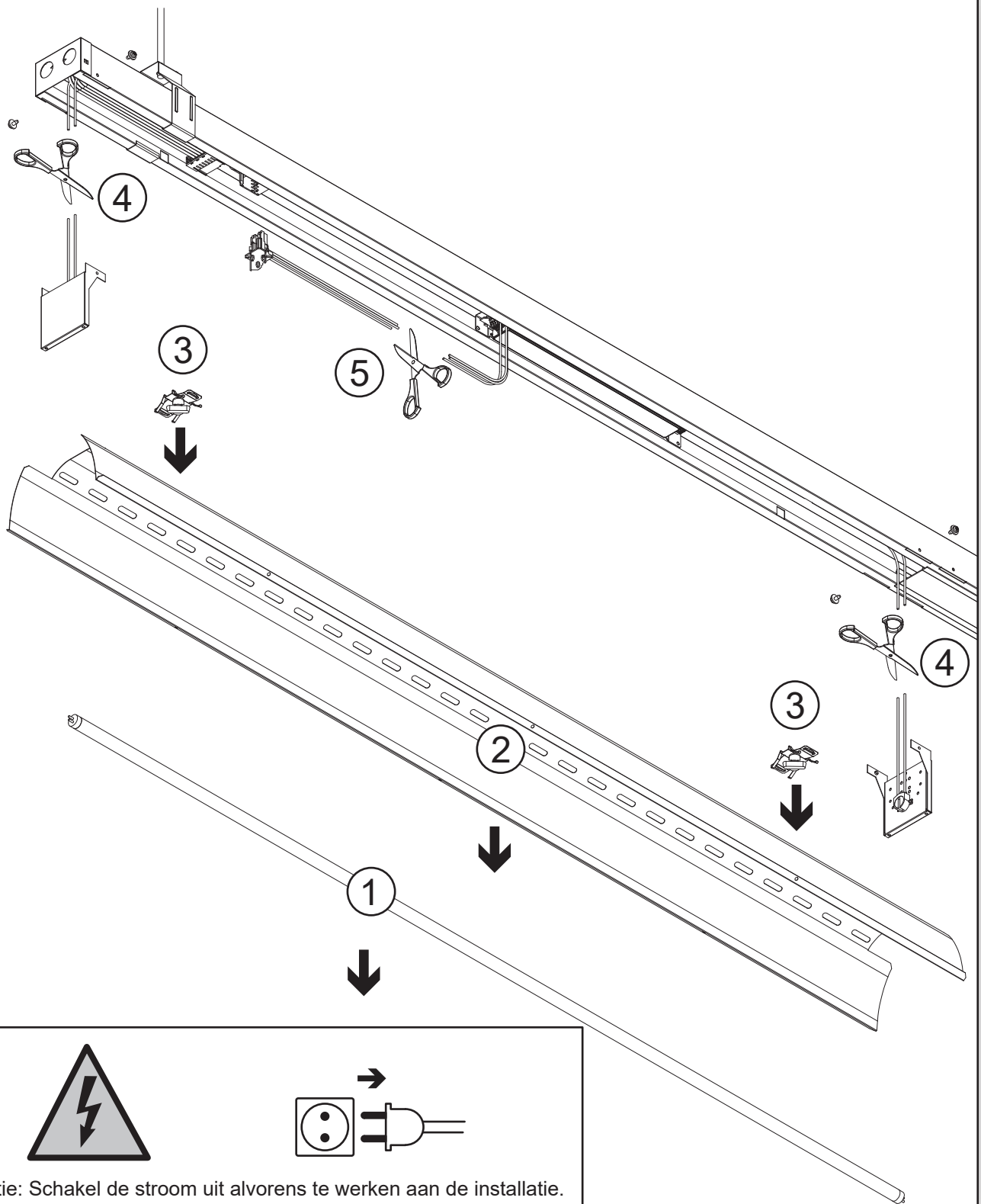

Attentie: Schakel de stroom uit alvorens te werken aan de installatie.  
Attention: Coupez l'alimentation avant de travailler sur l'installation.  
Attention: Disconnect power before working on the installation.  
Achtung: Schalten Sie den Strom vor Arbeiten an die Installation.  
Atención: Desconecte la corriente antes de trabajar en la instalación

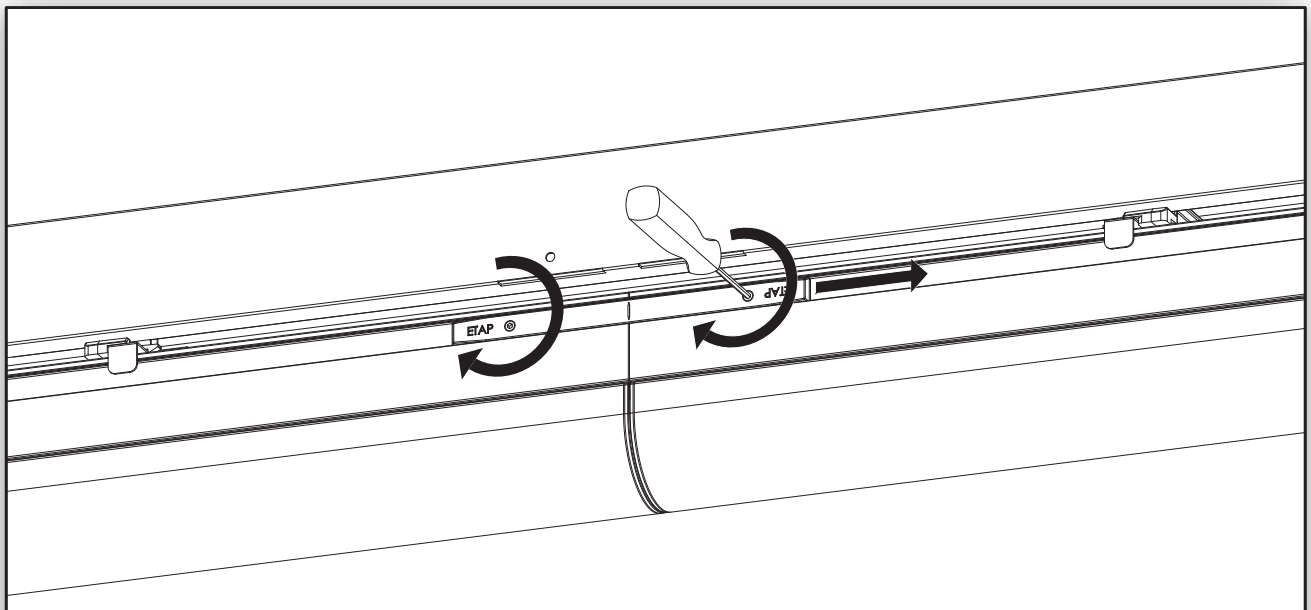
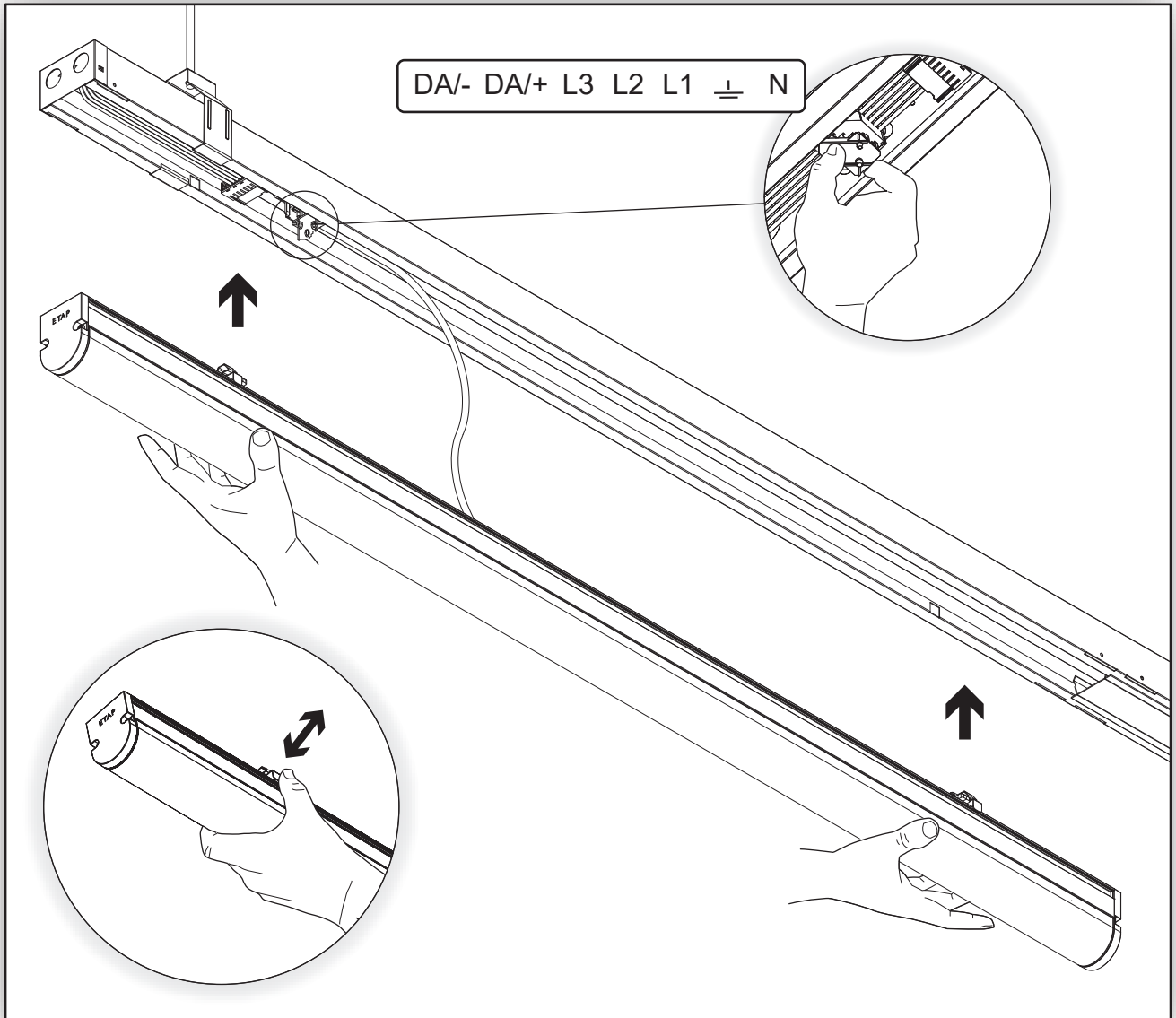

# INSTALLATIE | INSTALLATION | INSTALACION

## E5 FLUO > 2009

Renovatie / Rénovation / Renovation / Renovierung / Renovación  
Of / Ou / Or / Oder / O: E5A

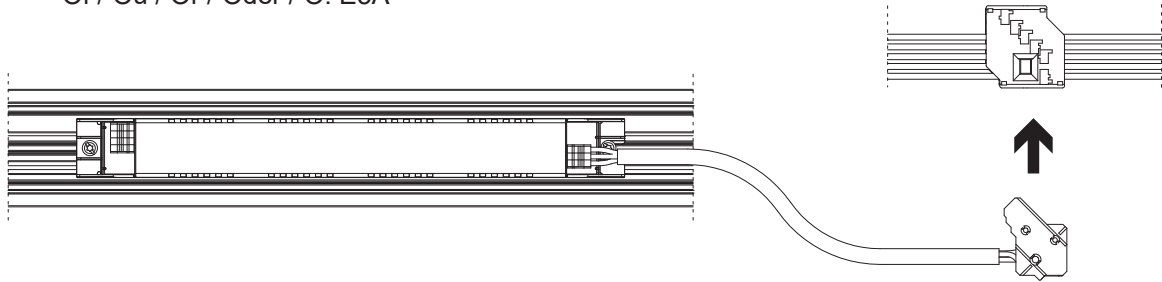

## E5 FLUO 1995 - 2009

Alleen renovatie / Seulement rénovation / Only renovation / Nur Renovierung / Sólo renovación

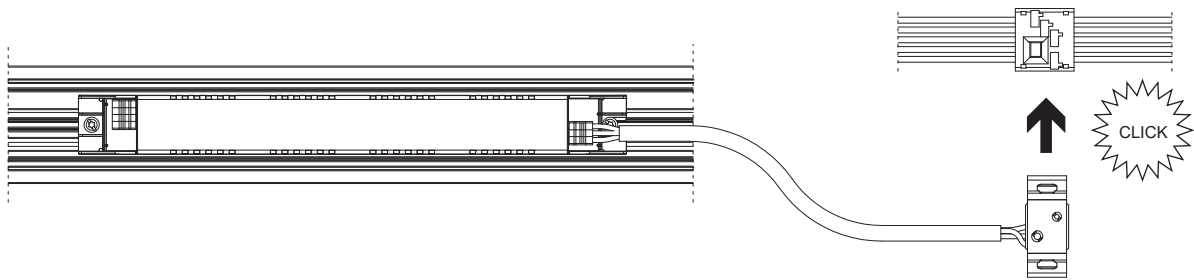

## E3 FLUO < 1995

Alleen renovatie / Seulement rénovation / Only renovation / Nur Renovierung / Sólo renovación

E3M

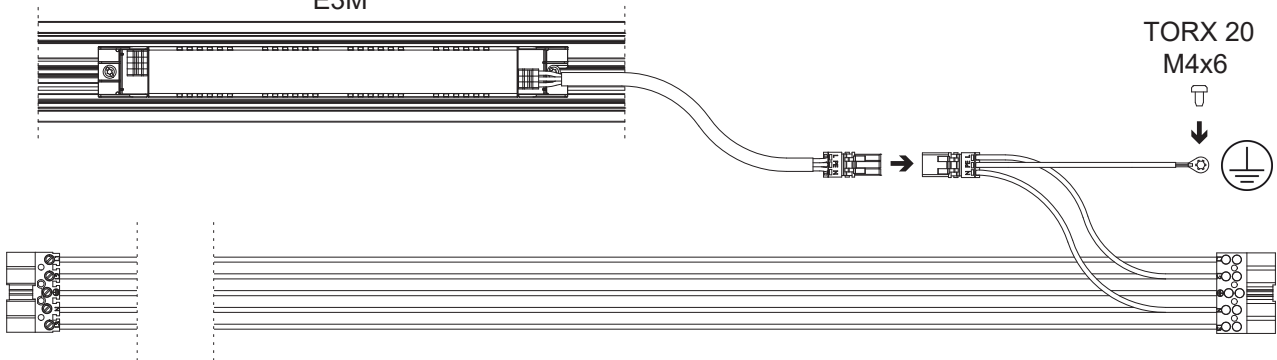

De gegevens in deze publicatie zijn zonder verbintenis en kunnen wijzigen ingevolge technische evolutie.

Les données dans cette publication sont sans engagement et peuvent subir des modifications en fonction de l'évolution technique.

Die in dieser Publikation verwendeten Daten sind unverbindlich und können sich infolge technischer Entwicklung verändern.

Information is provided without obligation, and may be modified as a result of technical developments.

Esta información no es carácter contractual y puede modificarse como resultado del desarrollo técnico.

E4E2991 - 06/2023