

E5B

ETAP tomorrow's light

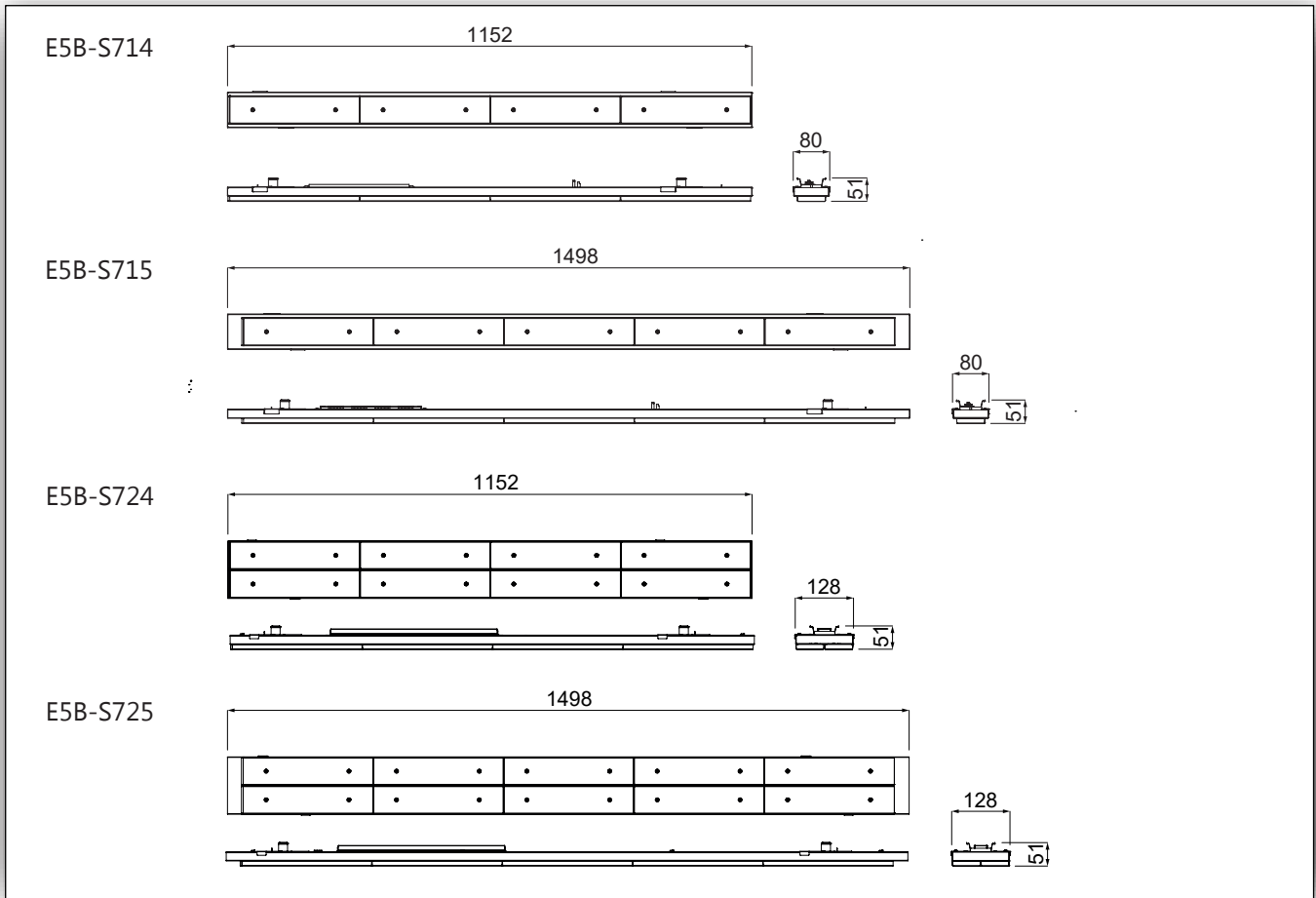
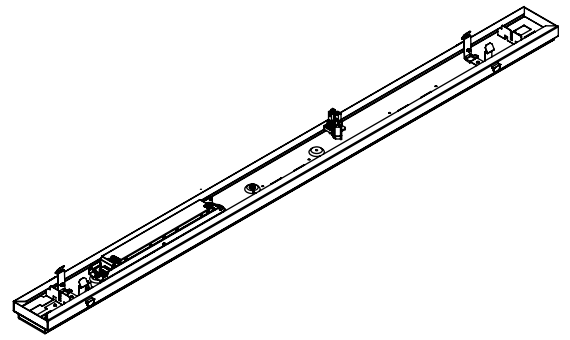

BELANGRIJK - IMPORTANT - ACHTUNG - IMPORTANTE

ELEKTRISCHE INSTALLATIE

Volg de aanduidingen in het armatuur

ELEKTRISCHER ANSCHLUSS

Beachten Sie die Angaben in der Leuchte.

RACCORDEMENT ELECTRIQUE

Suivez les indications dans le luminaire.

WIRING DIAGRAMS

Follow the indications in the luminaire.

DIAGRAMA DE CABLEADO

Seguir las indicaciones en la luminaria.

PLAATSING - EMPLACEMENT - ANORDNUNG - PLACING - COLOCACION

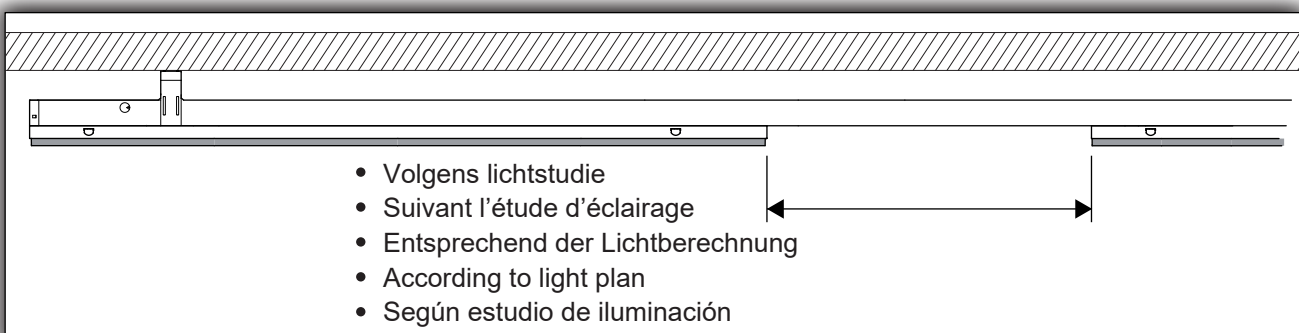

06/2020

E5E2420

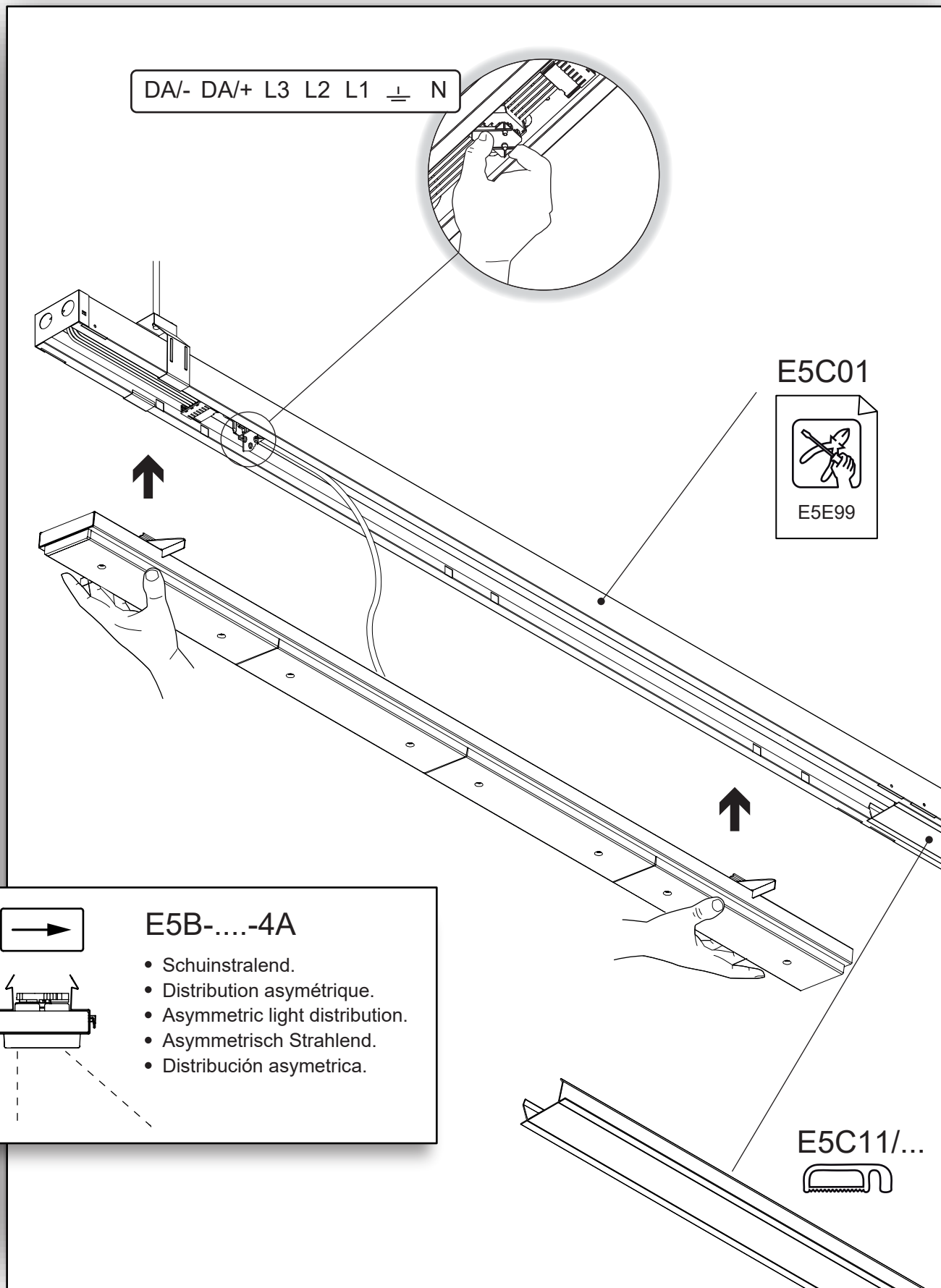

INSTALLATIE - INSTALLATION - INSTALACION

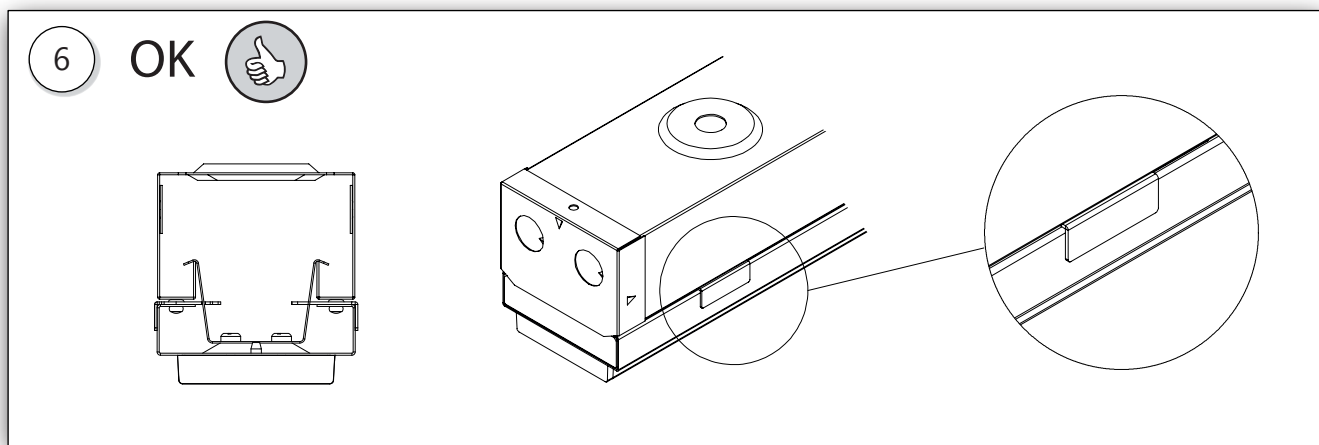
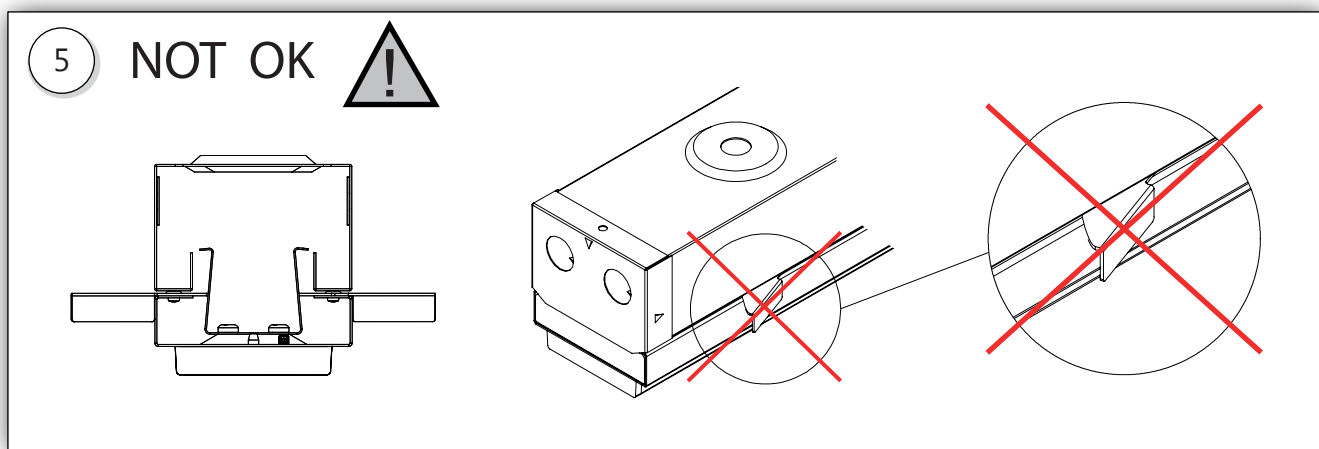
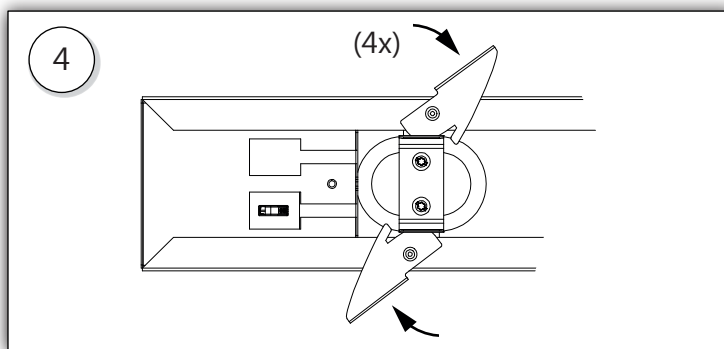
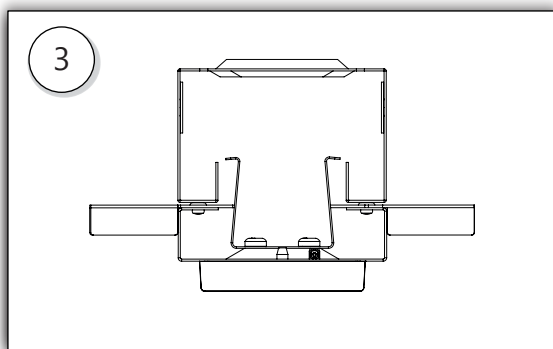
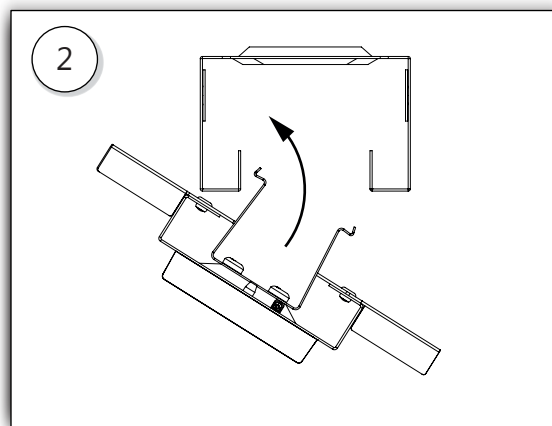
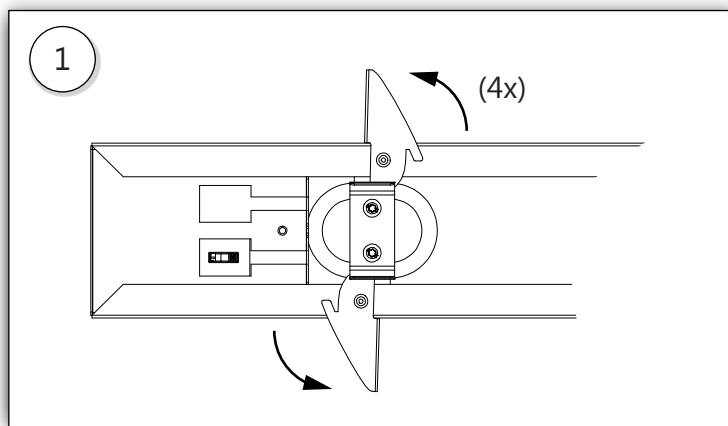

INSTALLATIE - INSTALLATION - INSTALACION

ALLEEN RENOVATIE - SEULEMENT RÉNOVATION - ONLY RENOVATION -
NUR RENOVIERUNG - SÓLO RENOVACIÓN

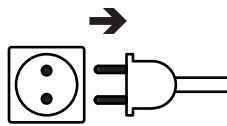
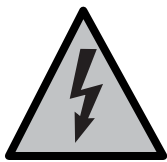
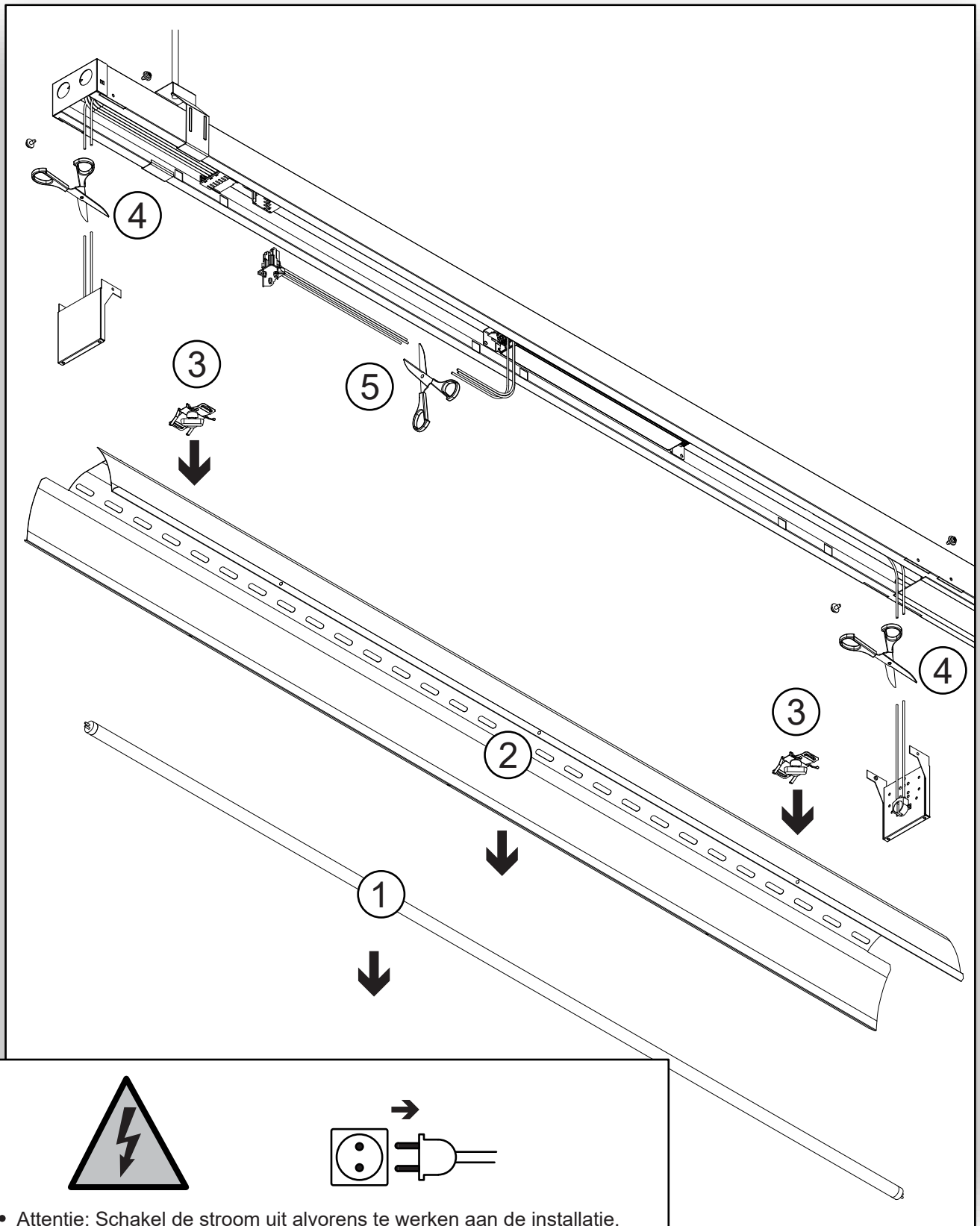

- Attention: Schakel de stroom uit alvorens te werken aan de installatie.
- Attention: Coupez l'alimentation avant de travailler sur l'installation.
- Attention: Disconnect power before working on the installation.
- Achtung: Schalten Sie den Strom vor Arbeiten an die Installation.
- Atención: Desconecte la corriente antes de trabajar en la instalación

INSTALLATIE - INSTALLATION - INSTALACION

E5 > 2009

Renovatie / R novation / Renovation / Renovierung / Renovaci n
Of / Ou / Or / Oder / O E5M + E5C01

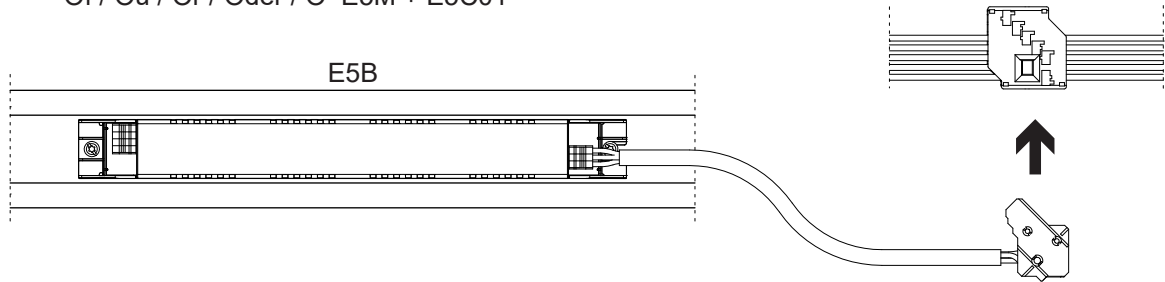

OPTION:

E5 1995 - 2009

Alleen renovatie / Seulement r novation / Only renovation / Nur Renovierung / S lo renovaci n

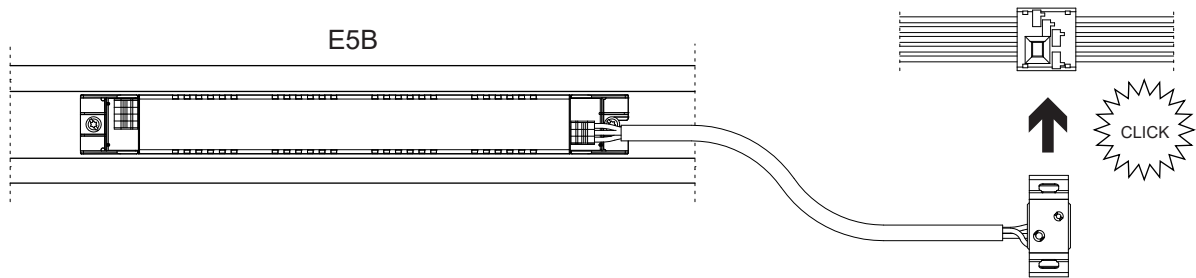

E3 < 1995

Alleen renovatie / Seulement r novation / Only renovation / Nur Renovierung / S lo renovaci n

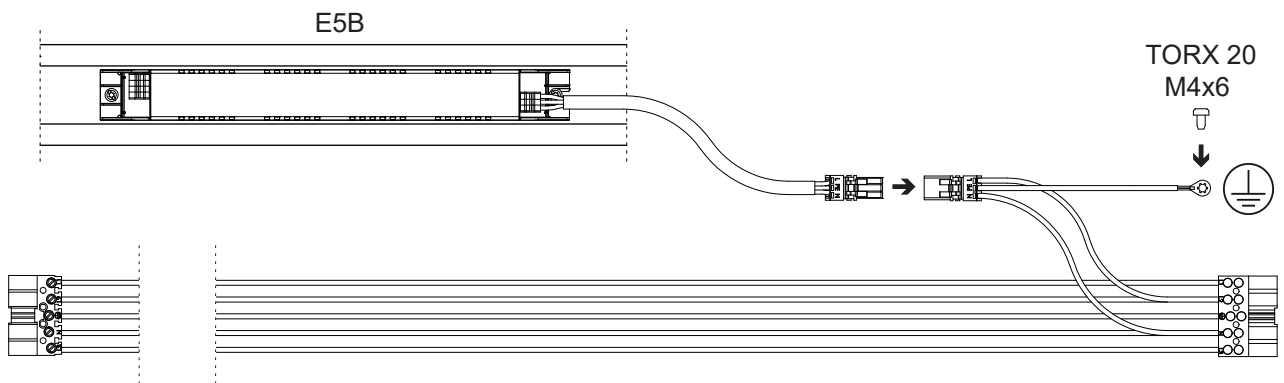

06/2020

E5E2420

INSTALLATIE - INSTALLATION - INSTALACION

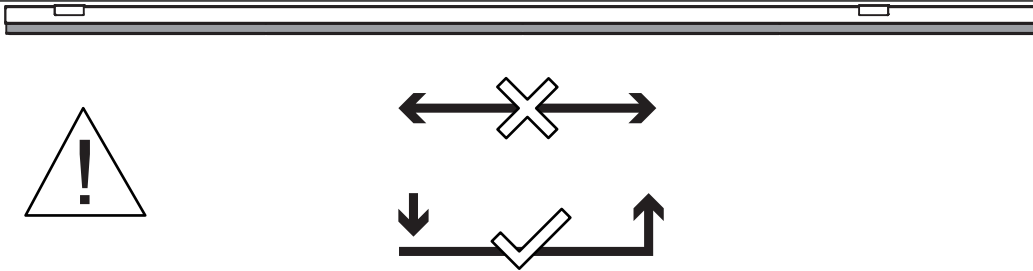



- Attention: Na installatie, modules niet verschuiven in de basis!
- Attention: Once installed, do not slide modules in base!
- Attention: une fois installés, ne pas glisser les modules!
- Achtung: Nach Installation Module in Basis nicht verschieben!
- Atención: Una vez instalados, ¡no deslizar los módulos por la base!

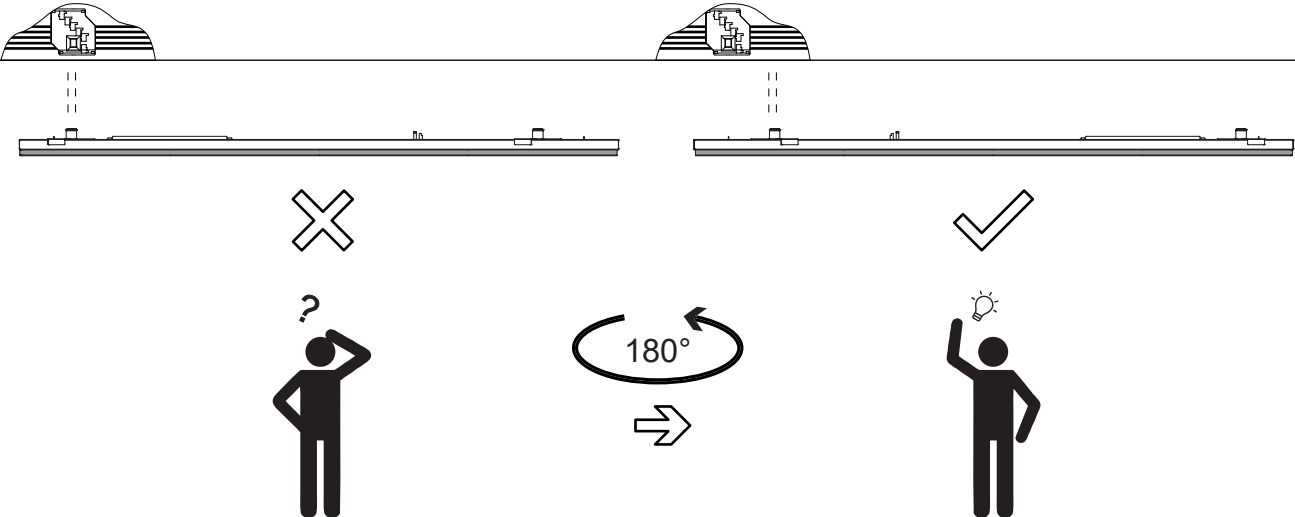

- Als de veer of driver raakt met de fasestekker, draai de module 180°
- If the spring or driver conflicts with the phase plug, rotate the module 180°
- Si le ressort ou le driver entre en conflit avec le sélectionneur de phase, tourner le module de 180°
- Falls Montagekonflikt von Federklemmen/Betriebsgerät im Modul mit Phasenwahlschaltersockel in der Basis besteht, Modul um 180° drehen
- Si el muelle o el driver chocan con el conector, gire el módulo 180°

De gegevens in deze publicatie zijn zonder verbintenis en kunnen wijzigen ingevolge technische evolutie.

Les données dans cette publication sont sans engagement et peuvent subir des modifications en fonction de l'évolution technique.

Die in dieser Publikation verwendeten Daten sind unverbindlich und können sich infolge technischer Entwicklung verändern.

Information is provided without obligation, and may be modified as a result of technical developments.

Esta información no es carácter contractual y puede modificarse como resultado del desarrollo técnico.