

# K28

ETAP   
EXCELLENT LIGHTING, SAVING ENERGY

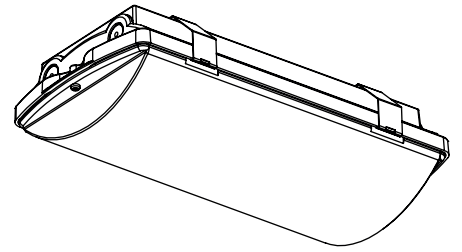

## VOORBEREIDING | PREPARATION | VORBEREITUNG | PREPARACIÓN

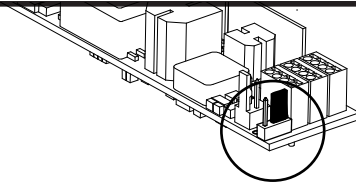
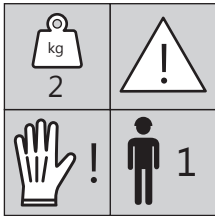
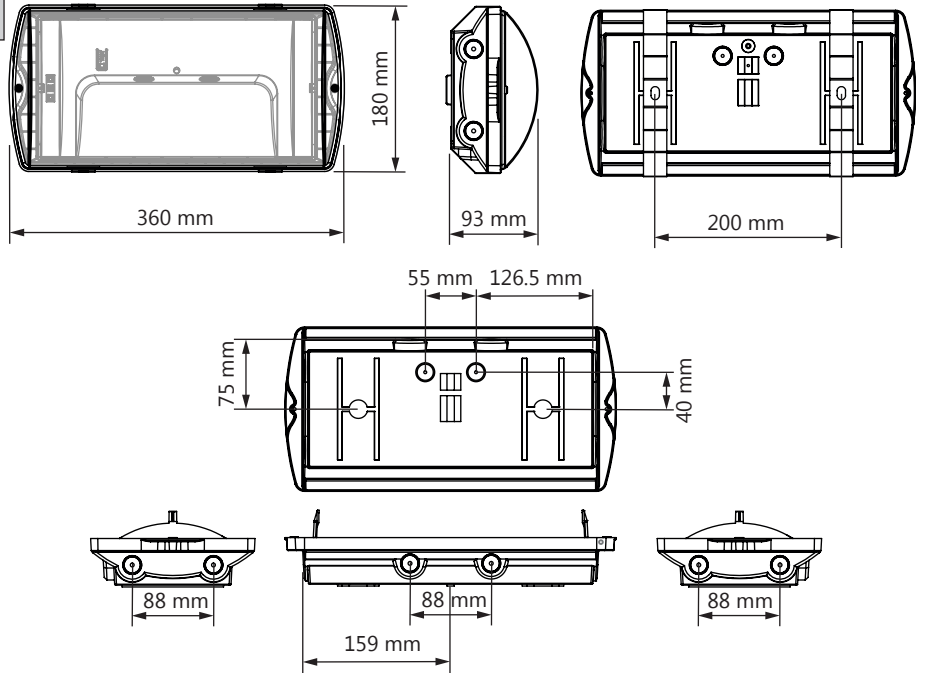

## MODE SETTINGS

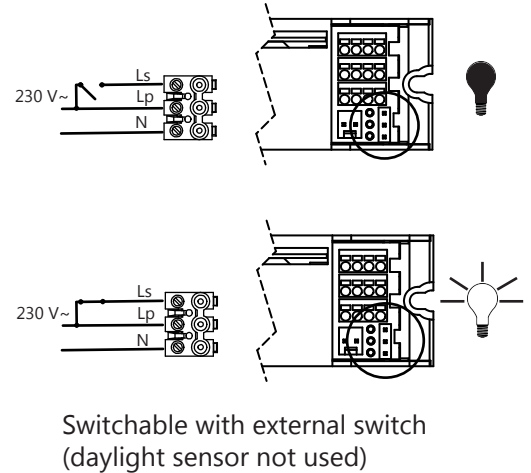
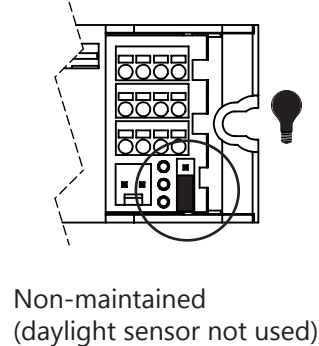
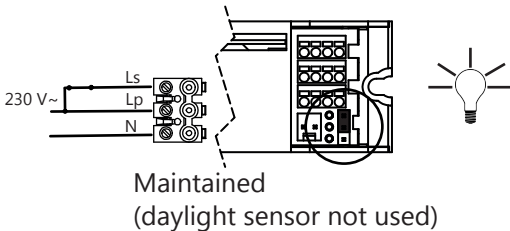
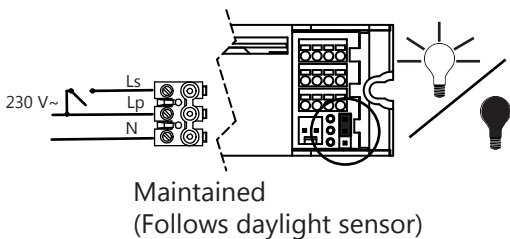

# INSTALLATIE | INSTALLATION | INSTALACIÓN

1

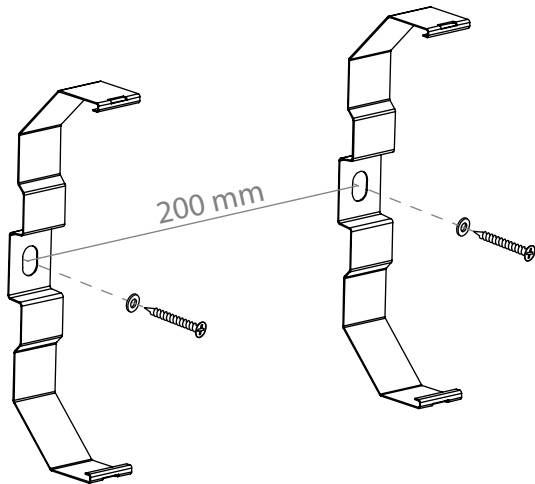

2

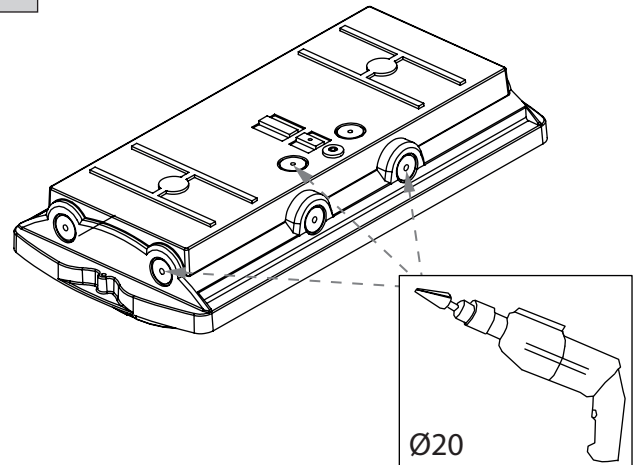

3

K2\*/\*230\*  
K2\*2/\*

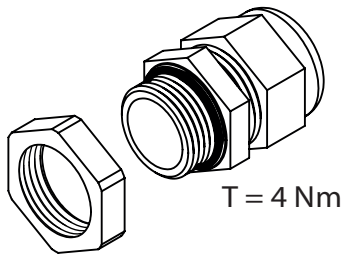

Cable diameter = 6 - 12 mm

Torque = T

K2\*3/\*  
K2\*4/\*

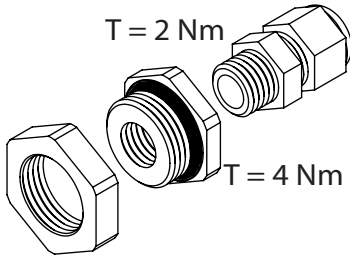

Cable diameter = 2 - 6,5 mm

Torque = T

4

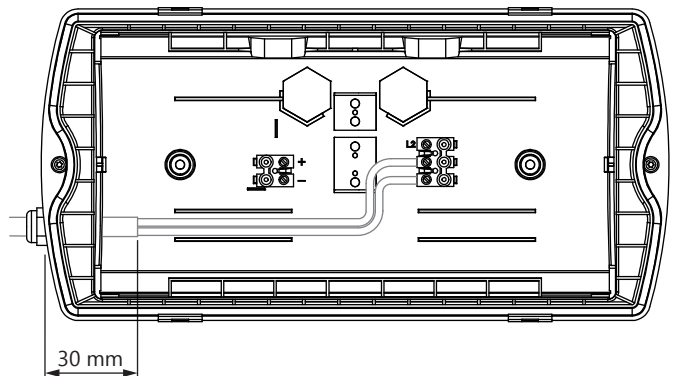
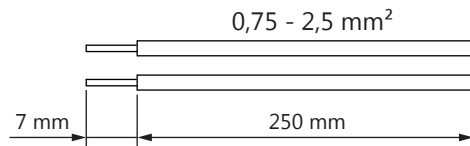

5

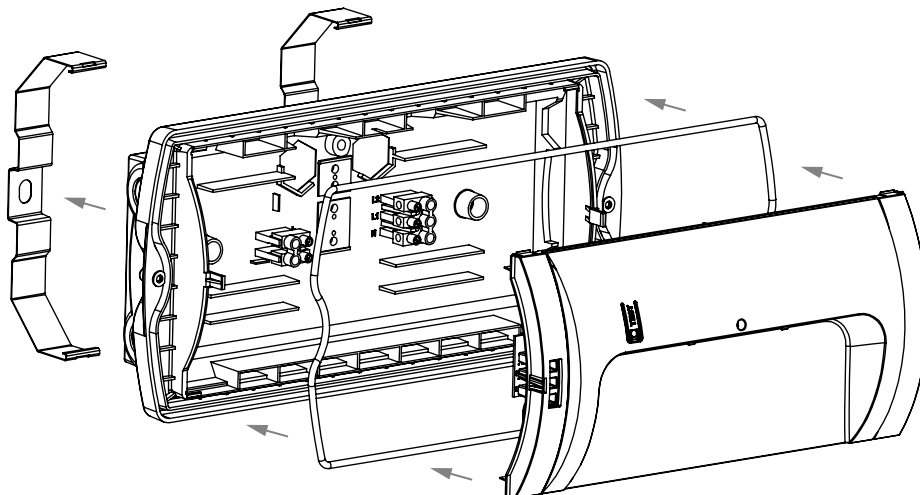

6

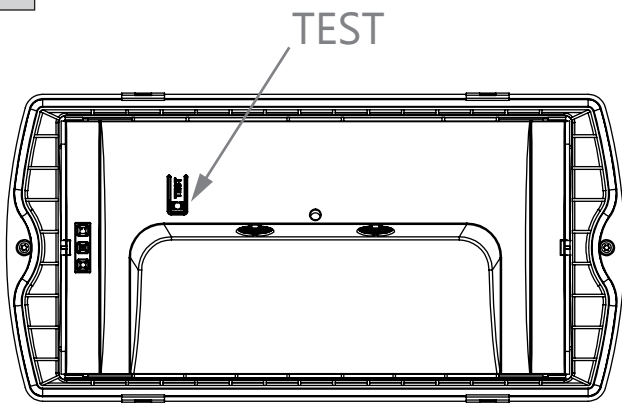

7

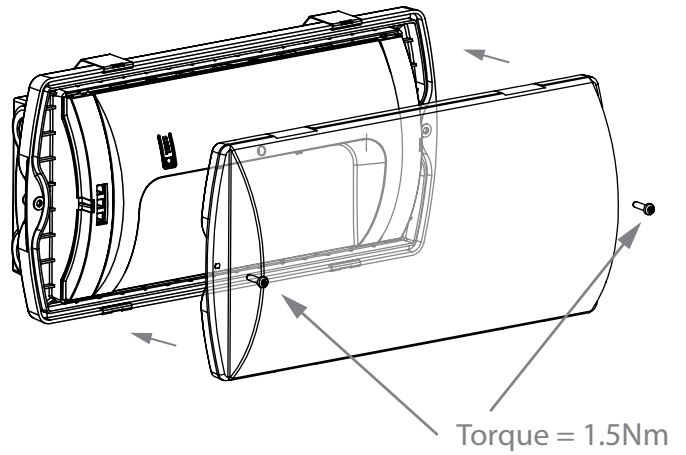

TOESTEL OPENEN | OUVRIER L'APPAREIL | DAS GERAT OFFNEN  
OPEN THE APPLIANCE | ABRA EL APARATO

1

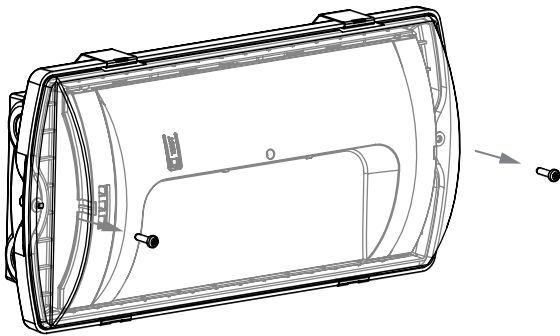

2

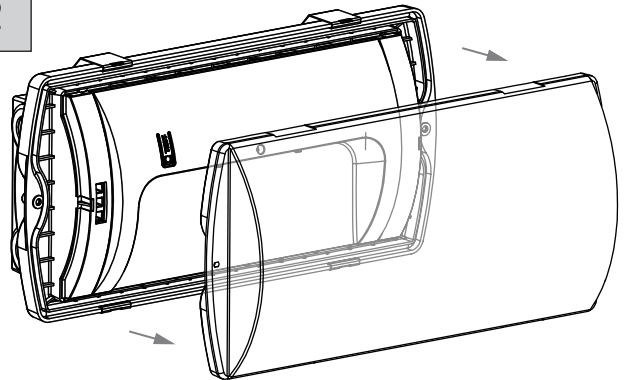

3

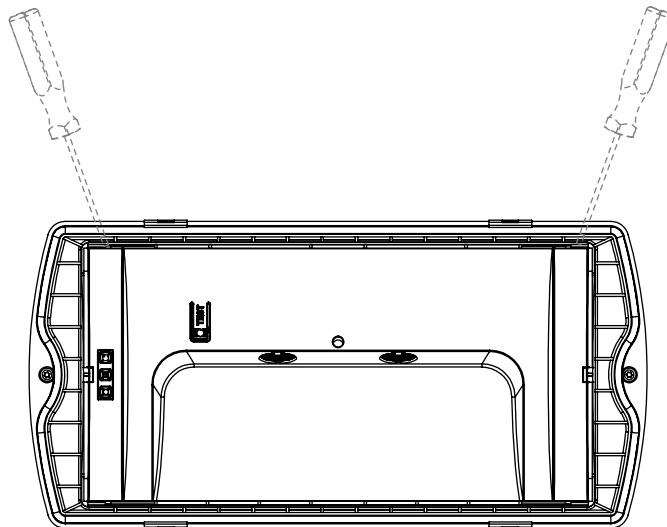

[www.etaplighting.com/downloads](http://www.etaplighting.com/downloads)

De gegevens in deze publicatie zijn zonder verbintenis en kunnen wijzigen ingevolge technische evolutie.

Les données dans cette publication sont sans engagement et peuvent subir des modifications en fonction de l'évolution technique.

Die in dieser Publikation verwendeten Daten sind unverbindlich und können sich infolge technischer Entwicklung verändern.

Information is provided without obligation, and may be modified as a result of technical developments.

Esta información no es carácter contractual y puede modificarse como resultado del desarrollo técnico.