

# K28\*S1

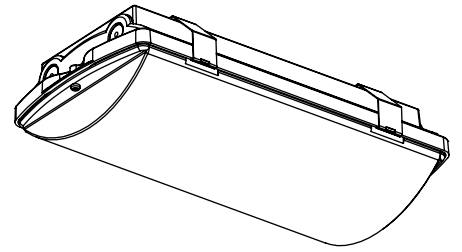

## VOORBEREIDING | PREPARATION | VORBEREITUNG | PREPARACIÓN

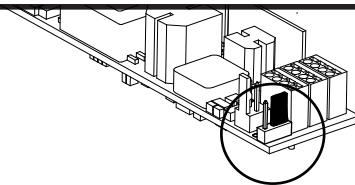
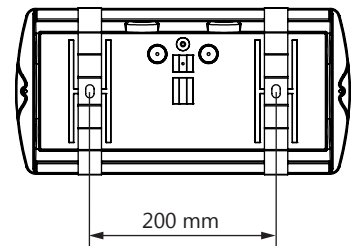
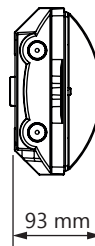
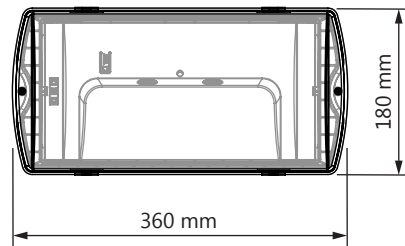
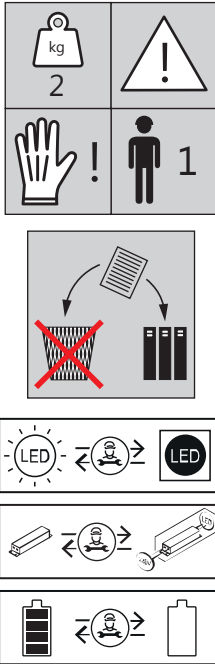

## MODE SETTINGS

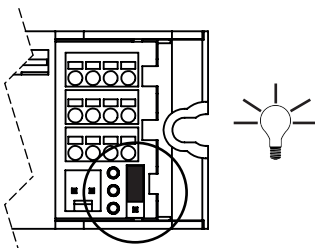

Maintained  
(Follows daylight sensor)

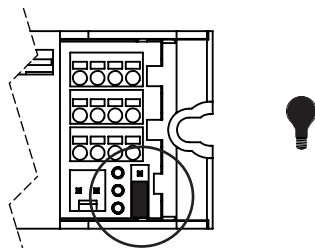

Non-maintained  
(daylight sensor not used)

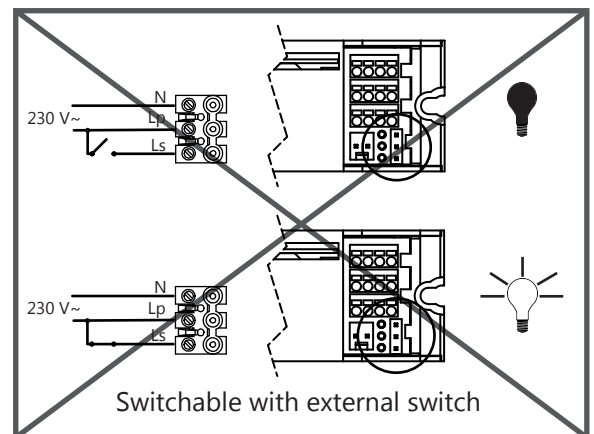

Switchable with external switch  
The external switching functionality is unavailable in this model.  
Contact ETAP for more information.

# INSTALLATIE | INSTALLATION | INSTALACIÓN

1

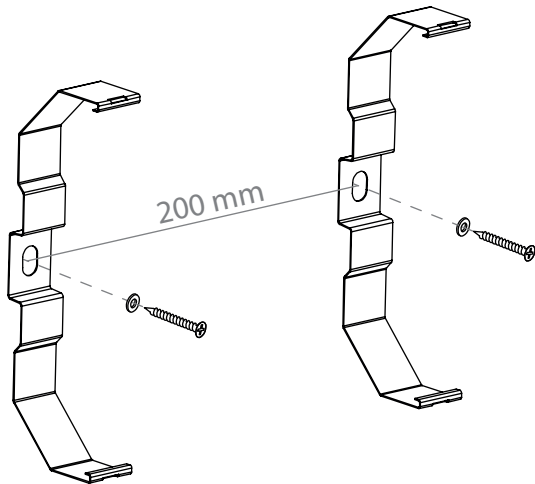

2

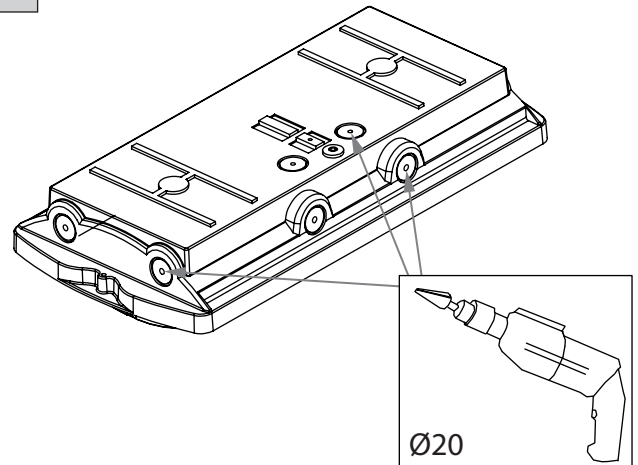

3

K2\*/\*230\*  
K2\*2/\*

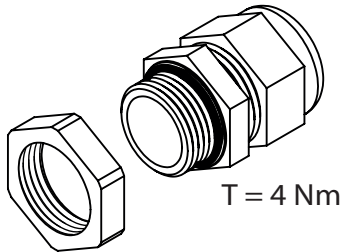

Cable diameter = 6 - 12 mm  
Torque = T

K2\*3/\*  
K2\*4/\*

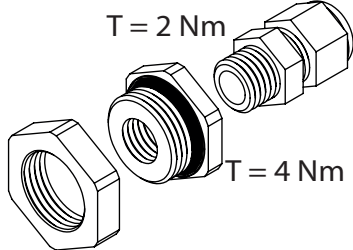

Cable diameter = 2 - 6,5 mm  
Torque = T

4

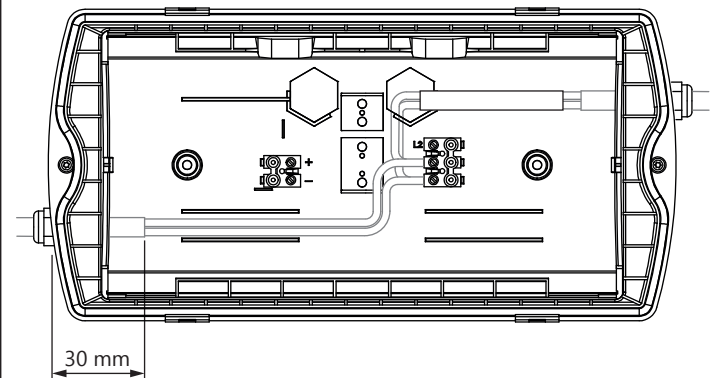
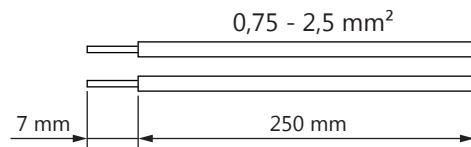

5

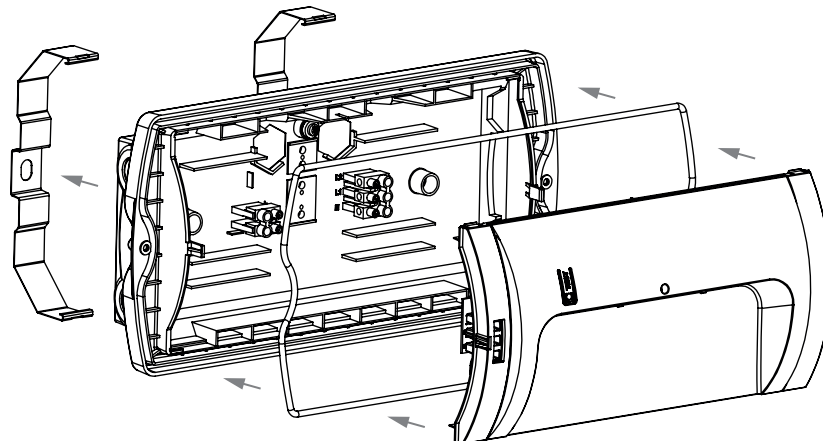

6

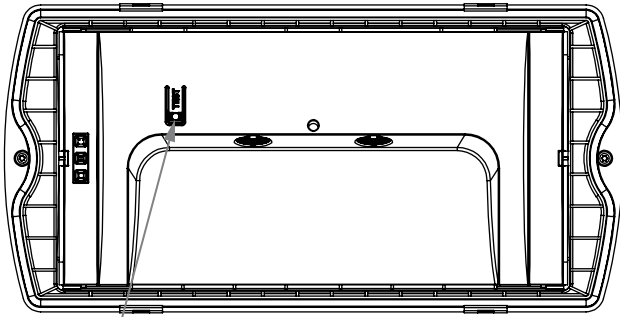

TEST

7

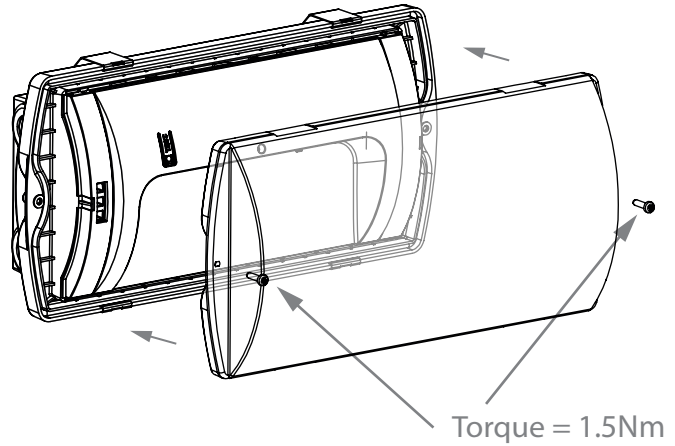

Torque = 1.5Nm

TOESTEL OPENEN | OUVRIR L'APPAREIL | DAS GERAT OFFNEN  
OPEN THE APPLIANCE | ABRA EL APARATO

1

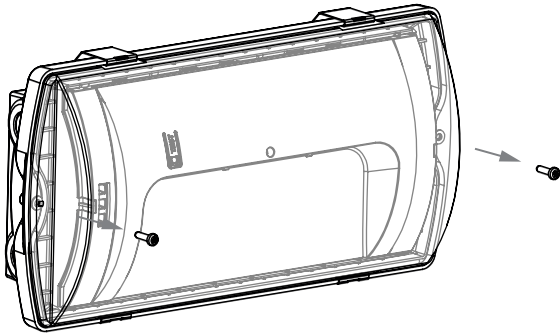

2

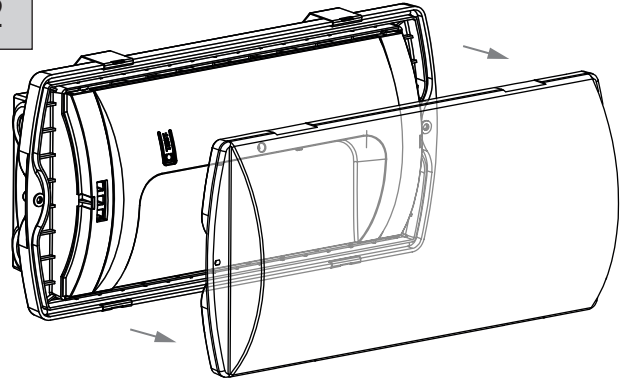

3

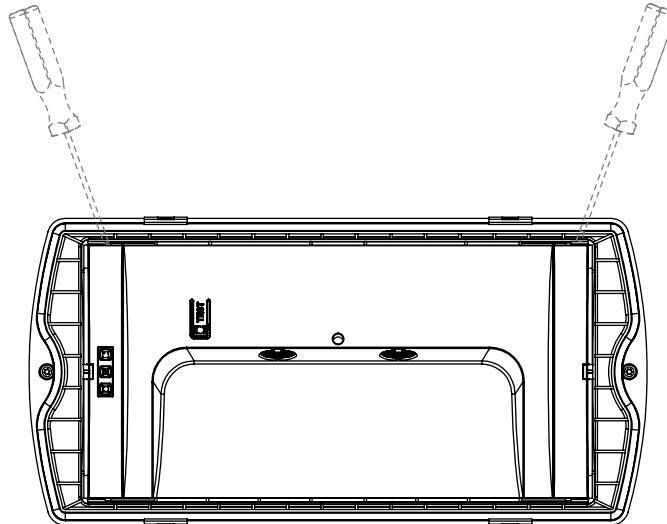

[www.etaplighting.com/downloads](http://www.etaplighting.com/downloads)

De gegevens in deze publicatie zijn zonder verbintenis en kunnen wijzigen ingevolge technische evolutie.

Les données dans cette publication sont sans engagement et peuvent subir des modifications en fonction de l'évolution technique.

Die in dieser Publikation verwendeten Daten sind unverbindlich und können sich infolge technischer Entwicklung verändern.

Information is provided without obligation, and may be modified as a result of technical developments.

Esta información no es carácter contractual y puede modificarse como resultado del desarrollo técnico.

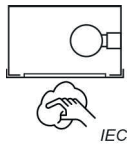
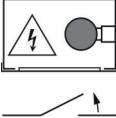
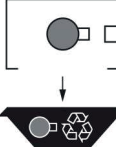
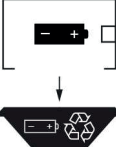
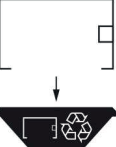
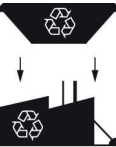
Instructions for luminaire cleaning	Instructions for end of life dismantling				
<div data-bbox="172 250 325 371" style="border: 1px solid black; padding: 5px; text-align: center;">Wipe outside optic</div> <div data-bbox="172 371 325 555" style="border: 1px solid black; padding: 5px;">  <p style="text-align: right; margin-right: 5px;">IEC</p> </div>	<b>Switch off</b> Switch off supply to luminaire	<b>Remove light source for recycling</b>	<b>Remove battery for recycling</b>	<b>Remove luminaire for recycling</b>	<b>Dispatch materials to recycling plant</b>
	 <p style="text-align: center; margin-top: 5px;">IEC</p>	 <p style="text-align: center; margin-top: 5px;">IEC</p>	 <p style="text-align: center; margin-top: 5px;">IEC</p>	 <p style="text-align: center; margin-top: 5px;">IEC</p>	 <p style="text-align: center; margin-top: 5px;">IEC</p>
IEC 62722-1 ed.2.0"Copyright © 2022 IEC Geneva, Switzerland. www.iec.ch					

ETAP Lighting International NV | Antwerpsesteenweg 130 - 2390 Malle - Belgium  
 Tel. +32 (0)3 310 02 11  
 www.etaplighting.com

"The author thanks the International Electrotechnical Commission (IEC) for permission to reproduce Information from its International Standards. All such extracts are copyright of IEC, Geneva, Switzerland. All rights reserved. Further information on the IEC is available from www.iec.ch. IEC has no responsibility for the placement and context in which the extracts and contents are reproduced by the author, nor is IEC in any way responsible for the other content or accuracy therein."