

# K9R2[1,2,6]

LIGHT  
SPOT

ETAP tomorrow's light

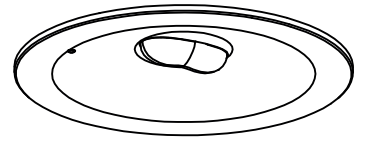

## INFORMATIE | INFORMATION | INFORMACIÓN

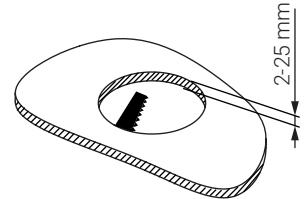
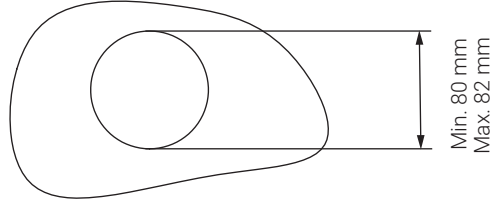
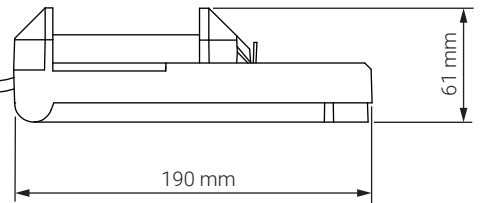
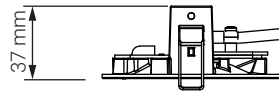
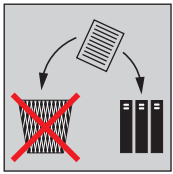
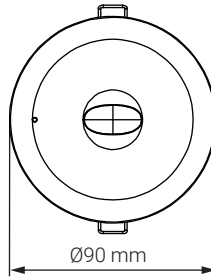

K9R21\*

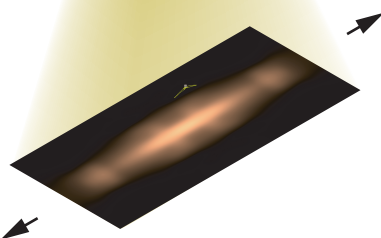
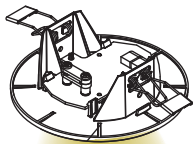
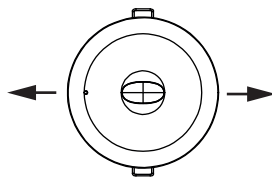

K9R22\*

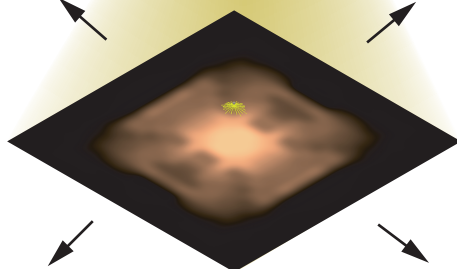
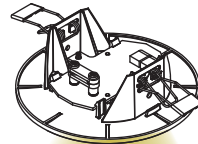
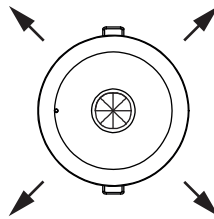

K9R26\*

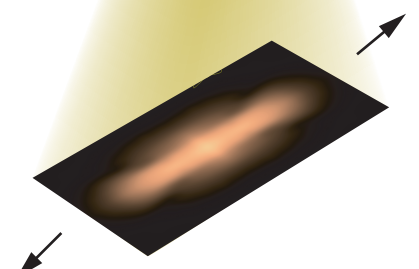
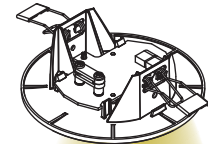
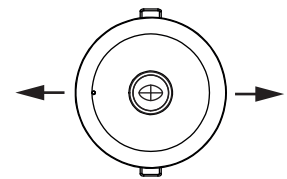

# INHOUDSTAFEL | TABLE DE MATIÈRES | INHALTSVERZEICHNIS | TABLE OF CONTENTS | TABELA DE CONTENIDOS

INFORMATIE   INFORMATION   INFORMACIÓN	1
IINHOUDSTAFEL   TABLE DE MATIÈRES   INHALTSVERZEICHNIS   TABLE OF CONTENTS   TABLA DE CONTENIDOS	2
ACCESSOIRES   ACCESSORIES   ZUBEHÖR   ACCESORIOS	2
AANSLUITSCHEMA   SCHÉMA DE CÂBLAGE   SCHALTPLAN   WIRING DIAGRAM   DIAGRA- MA DE CABLEADO	3
ELEKTRISCHE CONFIGURATIE   CONFIGURATION ELECTRIQUE   ELEKTRISCHE KONFIGURATION   ELECTRICAL CONFIGURATION   CONFIGURACIÓN ELÉCTRICA	3
INSTALLATIE   INSTALLATION   INSTALACIÓN	4
TOESTEL OPENEN   OUVRIER L'APPAREIL   DIE LEUCHTE ÖFFNEN OPEN THE APPLIANCE   ABRA EL APARATO	5
STUKLIJST   NOMENCLATURE   ERSATZTEILLISTE   SPARE PART LIST   LISTA DE PIEZAS DE REPUESTO	5
K9RH5	6
K9RH88	7
REPARATIE, DEMONTAGE EN RECYCLING   RÉPARATION, DE DÉMONTAGE ET DE RECYCLAGE   REPARATUR, DEMONTAGE UND RECYCLING   REPAIR, DISASSEMBLY AND RECYCLING   REPARACIÓN, DESMONTAJE Y RECICLAJE	8
ARMATUURREINIGING   NETTOYAGE DES LUMINAIRES   LEUCHTENREINIGUNG   LUMINAIRE CLEANING   LIMPIEZA DE LUMINARIAS	9
DEMONTAGE EINDE LEVENSDUUR   DÉMANTÈLEMENT EN FIN DE VIE   DEMONTAGE AM ENDE DER LEBENSDAUER   END OF LIFE DISMANTLING   DESMONTAJE FIN DE VIDA	9
OPGELET!   ATTENTION!   ACHTUNG!   CAUTION!   ATENCIÓN!	9

## ACCESSOIRES | ACCESSORIES | ZUBEHÖR | ACCESORIOS

K9RH5

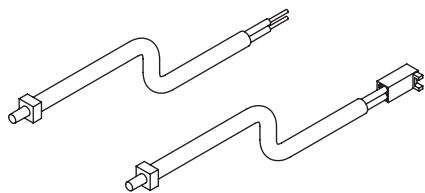

Testknop set  
Ensemble de boutons de test  
Testknopf Set  
Test button set  
Conjunto de botones de prueba

K9RH88

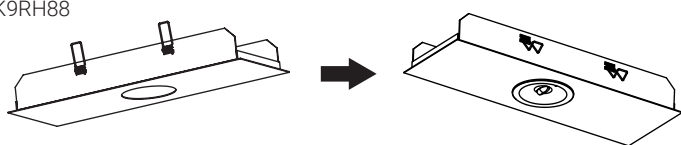

Adaptatieplaat voor K5 renovatie  
Plaque d'adaptation pour rénovation K5  
Anpassungsplatte für K5 Renovierung  
Adaptation plate for K5 renovation  
Placa de adaptación para la renovación K5

# AANSLUITSCHEMA | SCHÉMA DE CÂBLAGE | SCHALTPLAN | WIRING DIAGRAM | DIAGRAMA DE CABLEADO

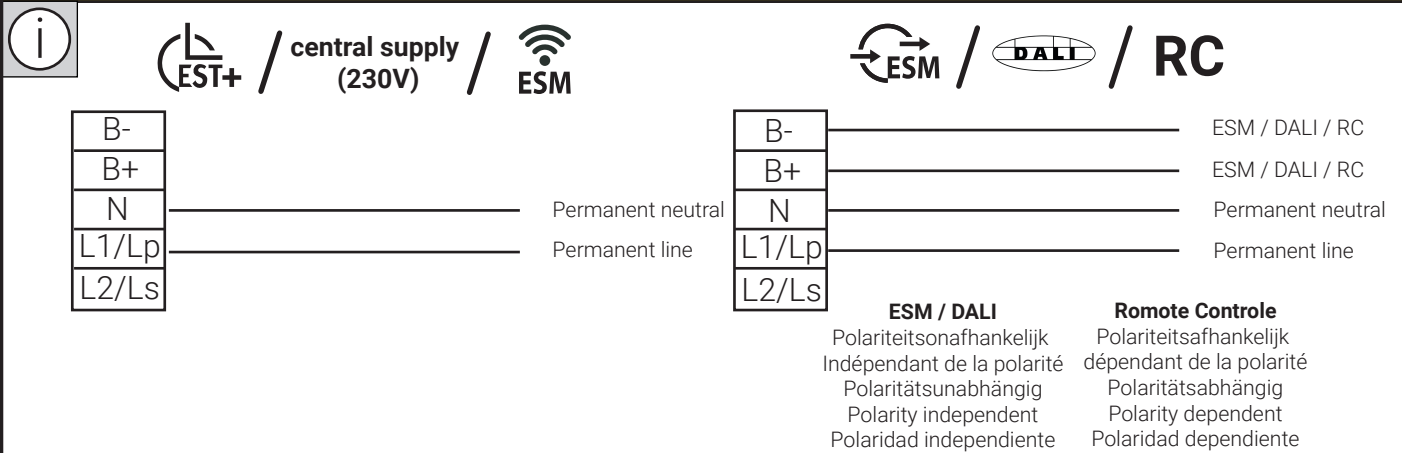

## ELEKTRISCHE CONFIGURATIE | CONFIGURATION ELECTRIQUE | ELEKTRISCHE KONFIGURATION | ELECTRICAL CONFIGURATION | CONFIGURACIÓN ELÉCTRICA

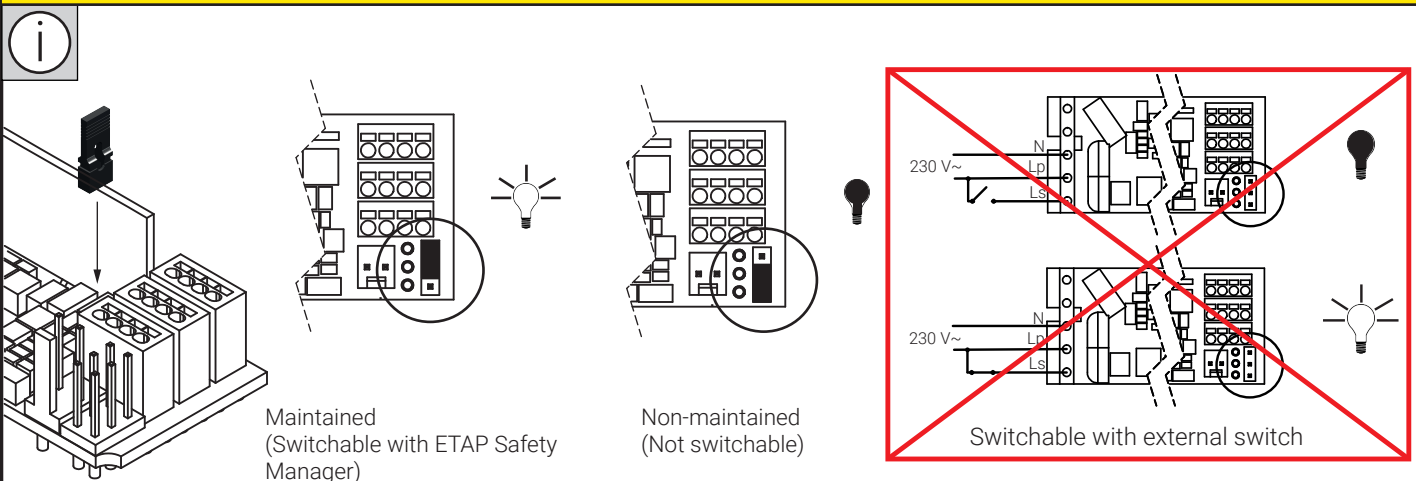

**!** \*De externe schakelfunctionaliteit is bij dit model niet beschikbaar. Contacteer ETAP voor meer informatie.

\*La fonctionnalité de commutation externe n'est pas disponible sur ce modèle. Contactez l'ETAP pour plus d'informations.

\*Die externe Schaltfunktion ist bei diesem Modell nicht verfügbar. Kontaktieren Sie ETAP für weitere Informationen.

\*The external switching functionality is unavailable in this model. Contact ETAP for more information.

\*La funcionalidad de conmutación externa no está disponible en este modelo. Póngase en contacto con ETAP para obtener más información.

+ **EST+** **DALI** **RC** **ESM** → [www.etaplighting.com/manuals](http://www.etaplighting.com/manuals)



# INSTALLATIE | INSTALLATION | INSTALACIÓN

1

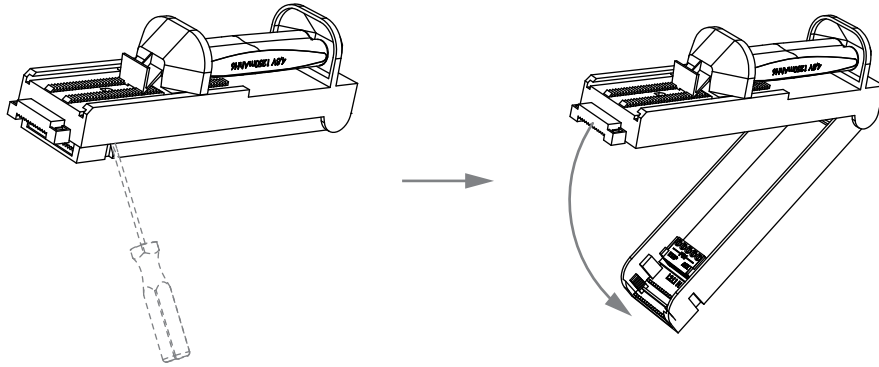

<https://youtu.be/ia6EHleDEwA>

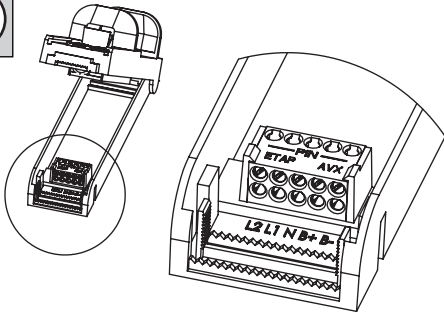

0,75 - 2,5 mm<sup>2</sup>

7 mm

15 - 25 mm



EST+ / central supply (230V) / ESM

ESM / DALI / RC

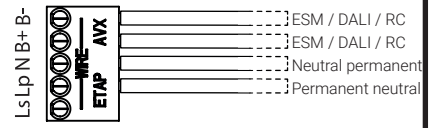
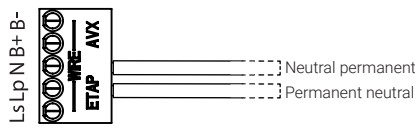

Doorvoer niet toegelaten  
Câblage traversant interdit  
Durchverdrahtung nicht erlaubt  
Through wiring not allowed  
Instalación pasante no permitida



2

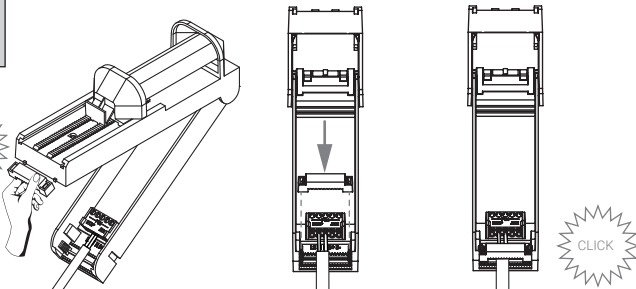

3

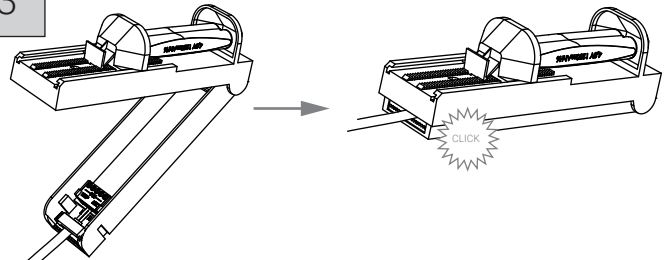

4

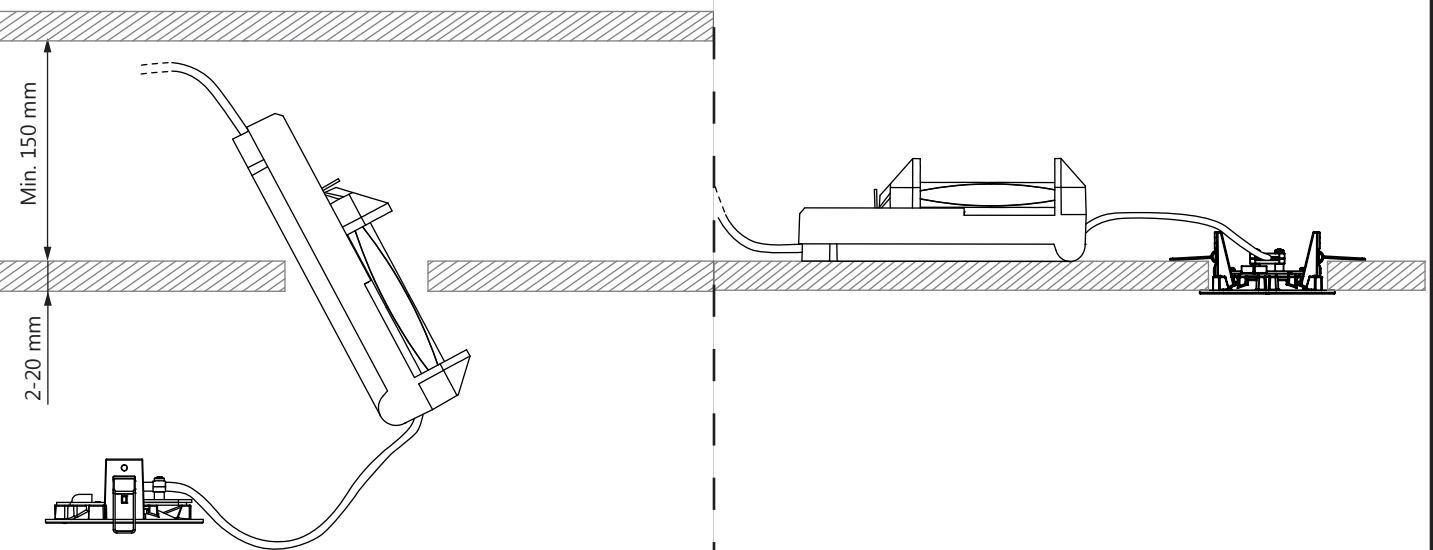

# TOESTEL OPENEN | OUVRIR L'APPAREIL | DIE LEUCHE ÖFFNEN OPEN THE APPLIANCE | ABRA EL APARATO

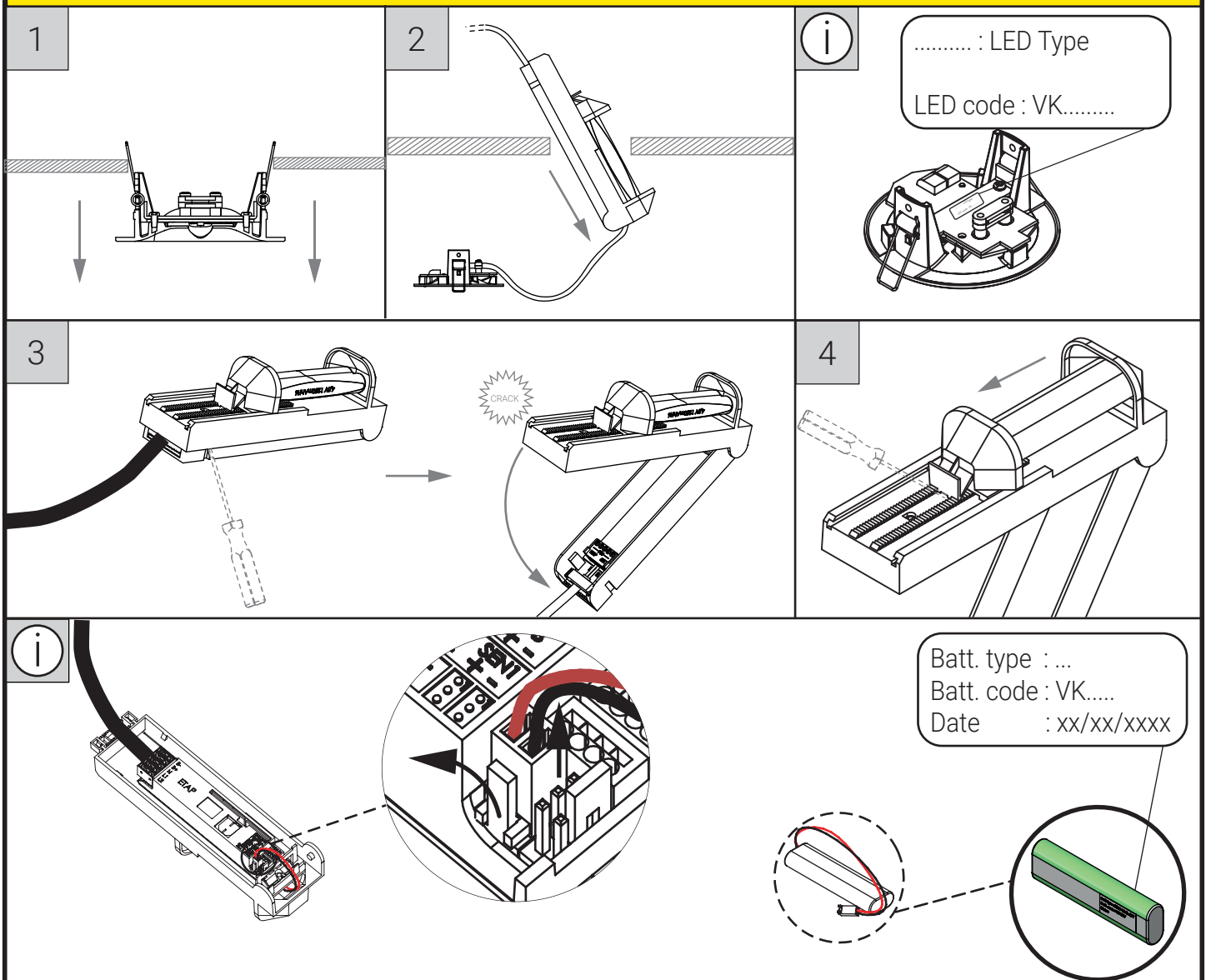

## STUKLIJST | NOMENCLATURE | ERSATZTEILLISTE | SPARE PART LIST | LISTA DE PIEZAS DE REPUESTO

BATTERY	EST+	ESM
	Zie batterijsticker na openen toestel Voir l'autocollant de la batterie après avoir ouvert l'appareil Batterieaufkleber erst nach dem Öffnen der Leuchte sichtbar See battery sticker after opening the appliance Ver etiqueta de batería después de abrir el dispositivo	Weergegeven in ESM systeem Affiché dans le système ESM Wird im ESM-System angezeigt Displayed in ESM system Mostrado en el sistema ESM
LED-module	EST+	ESM
	Zie LED-sticker na openen toestel Voir l'autocollant LED après avoir ouvert l'appareil LED-Beschriftung erst nach dem Öffnen der Leuchte sichtbar See LED sticker after opening the appliance Ver etiqueta LED después de abrir el dispositivo	Weergegeven in ESM systeem Affiché dans le système ESM Wird im ESM-System angezeigt Displayed in ESM system Mostrado en el sistema ESM

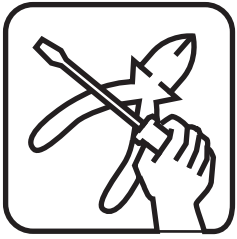

## K9RH5

Testknop set  
Ensemble de boutons de test  
Testknopf Set  
Test button set  
Conjunto de botones de prueba

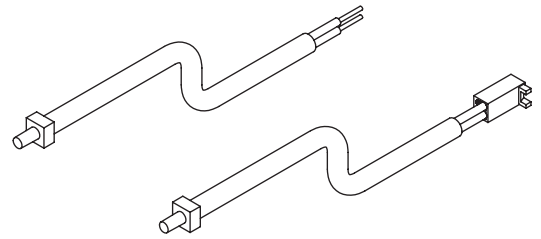

### VOORBEREIDING | PREPARATION | VORBEREITUNG | PREPARACIÓN

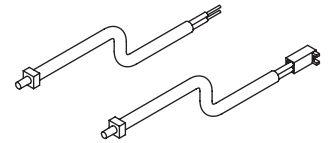
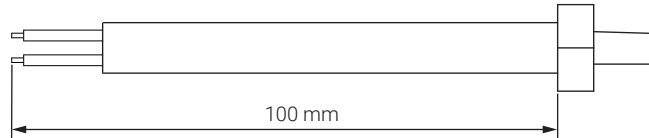

### INSTALLATIE | INSTALLATION | INSTALACIÓN

Voor installatie handleiding scan onderstaande QR code of raadpleeg de website.

Pour le manuel d'installation, scannez le code QR ci-dessous ou consultez le site Web.

Für die Installationsanleitung scannen Sie den untenstehenden QR-Code oder besuchen Sie die Website.

For installation manual, scan the QR code below or consult the website.

Para obtener el manual de instalación, escanee el código QR a continuación o consulte el sitio web.

## INSTALLATION MANUAL



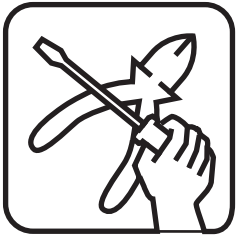

## K9RH88

Adaptatieplaat voor K5 renovatie  
Plaque d'adaptation pour rénovation K5  
Anpassungsplatte für K5 Renovierung  
Adaptation plate for K5 renovation  
Placa de adaptación para la renovación K5

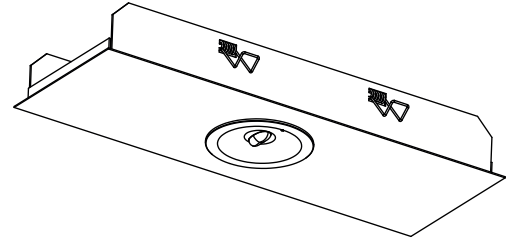

### VOORBEREIDING | PREPARATION | VORBEREITUNG | PREPARACIÓN

**i**

**i**

Ø109 mm  
140 mm  
398 mm  
123 mm  
55 mm  
384 mm

### INSTALLATIE | INSTALLATION | INSTALACIÓN

**1**

**2**

**3**

REPARATIE, DEMONTAGE EN RECYCLING  
 RÉPARATION, DE DÉMONTAGE ET DE RECYCLAGE  
 REPARATUR, DEMONTAGE UND RECYCLING  
 REPAIR, DISASSEMBLY AND RECYCLING  
 REPARACIÓN, DESMONTAJE Y RECICLAJE



STEEL



ZAMAK



WEEE



POLYCARBONATE

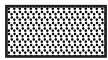

PMMA



BATTERY

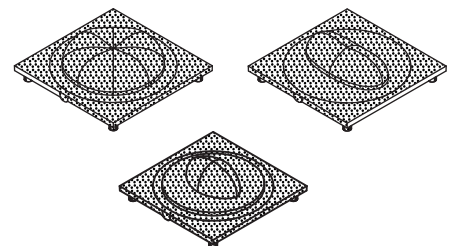
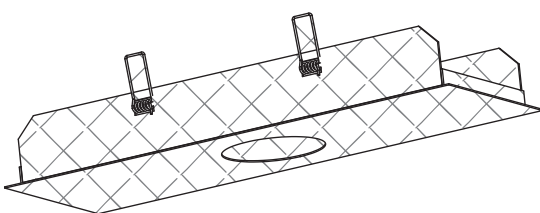
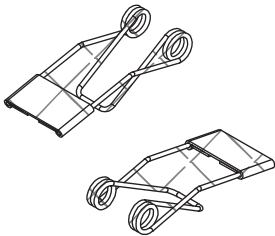
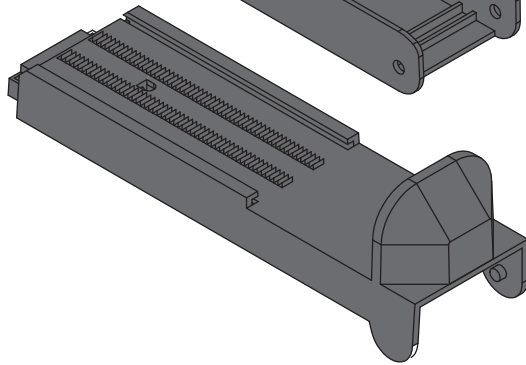
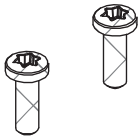
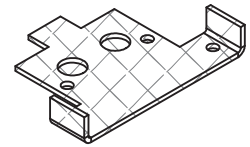
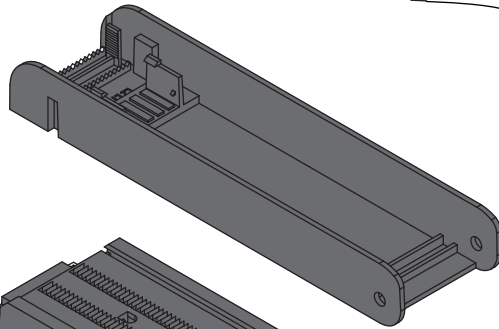
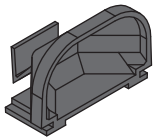
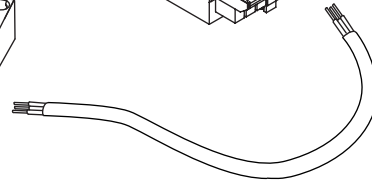
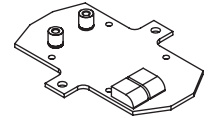
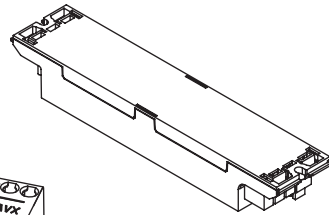
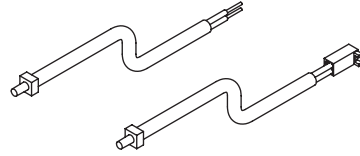



ARMATUURREINIGING |  
NETTOYAGE DES LUMINAIRES  
| LEUCHTENREINIGUNG |  
LUMINAIRE CLEANING |  
LIMPIEZA DE LUMINARIAS

DEMONTAGE EINDE LEVENSDUUR  
| DÉMANTÈLEMENT EN FIN DE VIE |  
DEMONTAGE AM ENDE DER LEBENSDAUER  
| END OF LIFE DISMANTLING |  
DESMONTAJE FIN DE VIDA

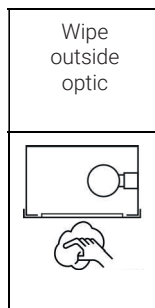

Switch off  
Switch off supply  
to luminaire

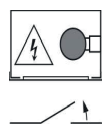

Remove light  
source for  
recycling

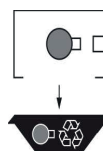

Remove battery  
for recycling

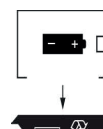

Remove luminaire  
for recycling



Dispatch materials  
to recycling plant

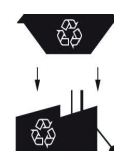

IEC 62722-1 ed.2.0 \*Copyright © 2022 IEC Geneva, Switzerland. www.iec.ch.

OPGELET! | ATTENTION! | ACHTUNG! | CAUTION! | ATENCIÓN!



De LED-lichtbron in deze armatuur mag uitsluitend worden vervangen door de fabrikant of een vergelijkbaar gekwalificeerd persoon.  
La source de lumière LED contenue dans ce luminaire ne doit être remplacée que par le fabricant ou une personne qualifiée similaire.  
Die in dieser Leuchte enthaltene LED-Lichtquelle darf nur vom Hersteller oder einer ähnlich qualifizierten Person ausgetauscht werden.  
The LED light source contained in this luminaire shall only be replaced by the manufacturer or a similar qualified person.  
La fuente de luz LED contenida en esta luminaria únicamente deberá ser reemplazada por el fabricante o una persona cualificada similar.



De batterij in dit armatuur mag uitsluitend worden vervangen door de fabrikant of een vergelijkbaar gekwalificeerd persoon.  
La batterie contenue dans ce luminaire ne doit être remplacée que par le fabricant ou une personne qualifiée similaire.  
Der in dieser Leuchte enthaltene Akku darf nur vom Hersteller oder einer ähnlich qualifizierten Person ausgetauscht werden.  
The battery contained in this luminaire shall only be replaced by the manufacturer or a similar qualified person.  
La batería contenida en esta luminaria sólo podrá ser reemplazada por el fabricante o una persona cualificada similar.

OPGELET!

- De aansluitleidingen voor sturingangen van dimbare EVSA's (1...10 V, DALI enz.) en voor andere controlesignalen moeten 230V-netspanningsvast zijn.
- De fabrikant is niet aansprakelijk voor schade als gevolg van onjuiste of ondeugdelijke installatie of bediening of van onbevoegde wijzigingen aan de armatuur.
- De armatuur wordt uitsluitend gebruikt voor verlichting en moet worden geïnstalleerd in overeenstemming met de nationale installatievoorschriften.

ATTENTION!

- Dimensionner les câbles d'alimentation pour les entrées de commande de ballasts électroniques dimmables (1...10 V, DALI etc.) en pour d'autres signaux de commande de manière qu'ils supportent une tension de secteur de 230 V.
- Le fabricant n'est pas responsable des dommages résultant d'une installation ou d'une utilisation incorrecte ou défectueuse ou de modifications non autorisées apportées au luminaire.
- Le luminaire est utilisé exclusivement pour l'éclairage et doit être installé conformément aux réglementations nationales en matière d'installation.

ACHTUNG!

- Anschlussleitungen für Steuereingänge dimmbarer EVG (1...10 V, DALI etc.) und andere Steuersignale 230 V- netzspannungsfest auslegen.
- Der Hersteller haftet nicht für Schäden, die durch unsachgemäße oder fehlerhafte Installation oder Bedienung oder durch eigenmächtige Veränderungen an der Leuchte entstehen.
- Die Leuchte dient ausschließlich der Beleuchtung und ist gemäß den nationalen Installationsvorschriften zu installieren.

CAUTION!

- Use mains cables for control inputs of dimmable ECG (1...10 V, DALI, etc.) and for other control signals which are rated for 230 V.
- The manufacturer is not liable for damages resulting from improper or faulty installation or operation or from unauthorized modifications to the luminaire.
- The luminaire is used exclusively for lighting and is to be installed in accordance with the national installation regulations.

ATENCIÓN!

- Los cables de alimentación de los balastos electrónicos regulables para las entradas de control (1...10V, DALI, etc.) y otras señales de control 230 V deben colocarse con tensión estable.
- El fabricante no se hace responsable de los daños derivados de una instalación o un funcionamiento inadecuados o defectuosos o de modificaciones no autorizadas de la luminaria.
- La luminaria se utiliza exclusivamente para la iluminación y debe instalarse de acuerdo con las normas nacionales de instalación.

CUIDADO!

- Use cabos de alimentação para entradas de controle de ECG regulável (1...10 V, DALI, etc.) e para outros sinais de controle classificados para 230 V.
- O fabricante não se responsabiliza por danos resultantes de instalação ou operação inadequada ou defeituosa ou de modificações não autorizadas na luminária.
- A luminária é utilizada exclusivamente para iluminação e deve ser instalada de acordo com os regulamentos de instalação nacionais.

VARNING!

- Använd nätkablar för styringångar för dimbart EKG (1...10 V, DALI, etc.) och för andra styrsignaler som är klassade för 230 V.
- Tillverkaren ansvarar inte för skador som uppstår på grund av felaktig eller felaktig installation eller funktion eller från obehöriga modifieringar av armaturen.
- Armaturen används uteslutande för belysning och ska installeras i enlighet med nationella installationsföreskrifter.

ETAP Lighting International NV | Antwerpsesteenweg 130 - 2390 Malle - Belgium

Tel. +32 (0)3 310 02 11

www.etaplighting.com

"The author thanks the International Electrotechnical Commission (IEC) for permission to reproduce Information from its International Standards. All such extracts are copyright of IEC, Geneva, Switzerland. All rights reserved. Further information on the IEC is available from www.iec.ch. IEC has no responsibility for the placement and context in which the extracts and contents are reproduced by the author, nor is IEC in any way responsible for the other content or accuracy therein."