

U23

Option IP54

ETAP 
EXCELLENT LIGHTING, SAVING ENERGY

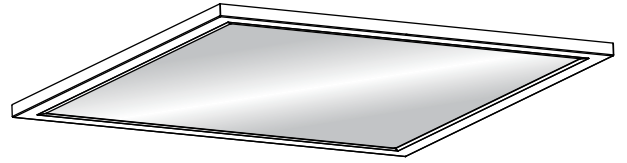

VOORBEREIDING | PREPARATION | VORBEREITUNG | PREPARACIÓN

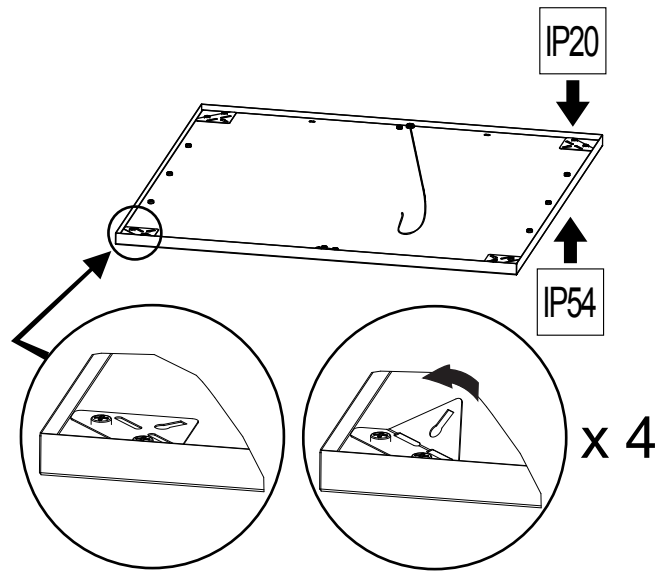
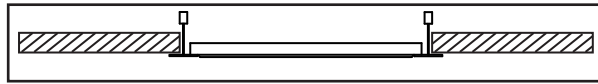

	L	W	H
M600	596	596	14
M625	621	621	14
M300	1196	296	14

INSTALLATIE | INSTALLATION | INSTALACIÓN

1

